

# How to build a fibre network

---

**Developer Guide**

Version 9.1 • October 2019





# Contents

**01 Internal equipment**

---

**02 Home wiring**

---

**03 Developer self-install**

---

**04 Cabling and ONT positioning**

---

**05 Multi dwelling Units (MDUs)**

---

**06 Commercial units**

---

**07 Duct laying**

---

**08 Modular jointing chambers – Quadbox™**

---

**09 Joint boxes, footways and frames & covers**

---

**10 List of abbreviations and acronyms**

---

**11 Health and safety advice**

---

**12 Quality control checklist**

---

**13 ONT plot stickers**

# 1 Internal equipment

## Openreach Optical Network Termination (ONT) and enclosure

The ONT is the Openreach demarcation point. It replaces the traditional copper master socket.

The Openreach ONT sits in an enclosure providing space to manage the wiring, keeping everything neat and tidy. The enclosure is designed for simple wall mounting with just 2 screws.

- Optical port connects to the connectorised internal fibre cable
- Ethernet port connects to the communications provider's (CP) router.
- Telephony port connects to voice network.

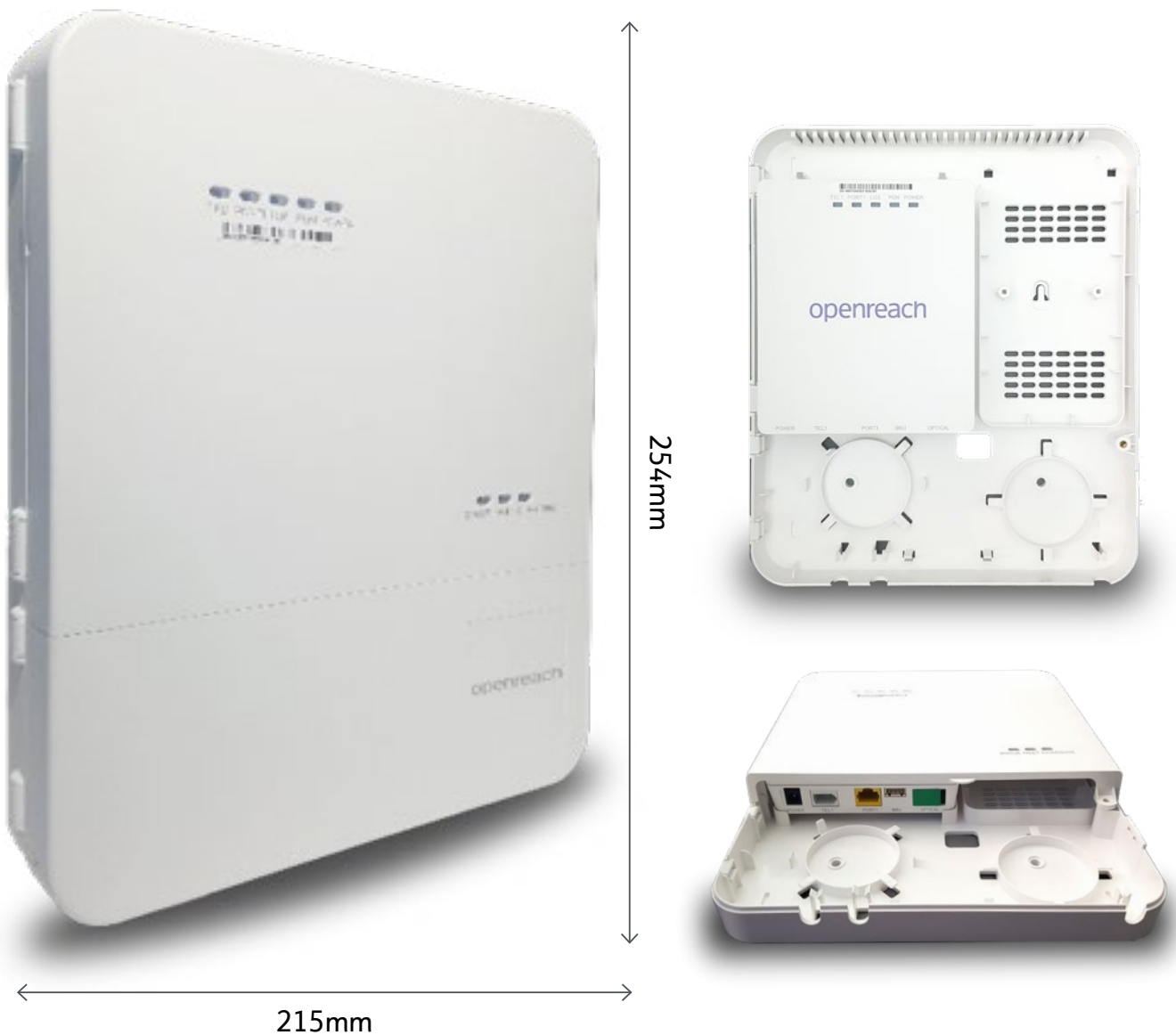

## 2 Home wiring

The wiring that you install in your customer's properties is pivotal to their experience.

### Your options in the installation of internal wiring are shown as below

#### Implications of locating the service provider's router in a cupboard

It is important to note that the Wi-Fi service your customer receives is dependent upon the intended location of the communication provider's router. Placing the router in a service cupboard or under stairs cupboard will significantly reduce the speed and coverage your customer will receive.

It is highly recommended that if you position the router in this way that you provide additional RJ45 ports within the home.

Ideally for optimum speeds to be enjoyed using Wi-Fi service it is recommended that you locate the router centrally within the property.

For information, advice and guidance around positioning, please refer to: PAS: 2016 Next Generation Access for new Build Homes Guide.

#### Please note

All internal wires and sockets beyond the ONT are the responsibility of the developer/ future home owner.

If any part of the connectorised internal fibre cable is found to be damaged at commissioning, it is the developer's responsibility to replace it.

If the homeowner experiences a lack of service or poor service, which is due to a fault within the internal installation of wiring, which requires Openreach to rectify, the homeowner will be charged.

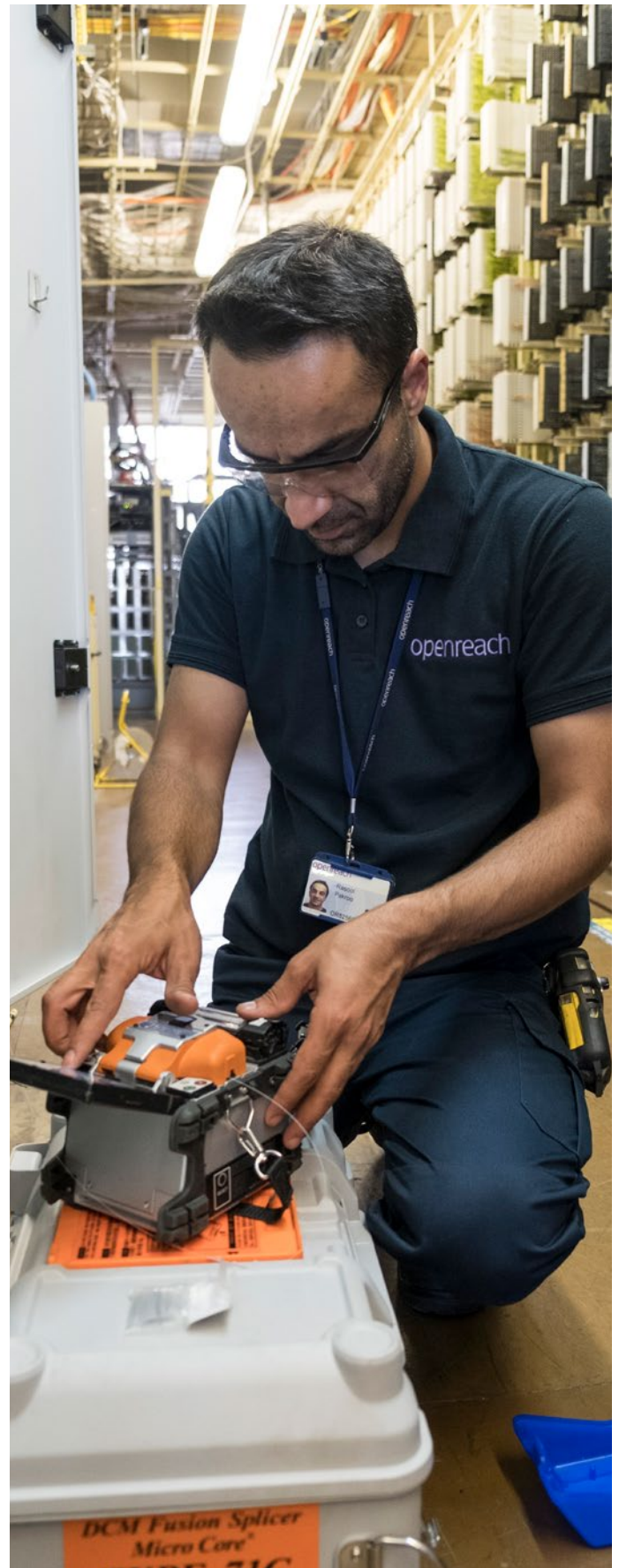

## Home wiring

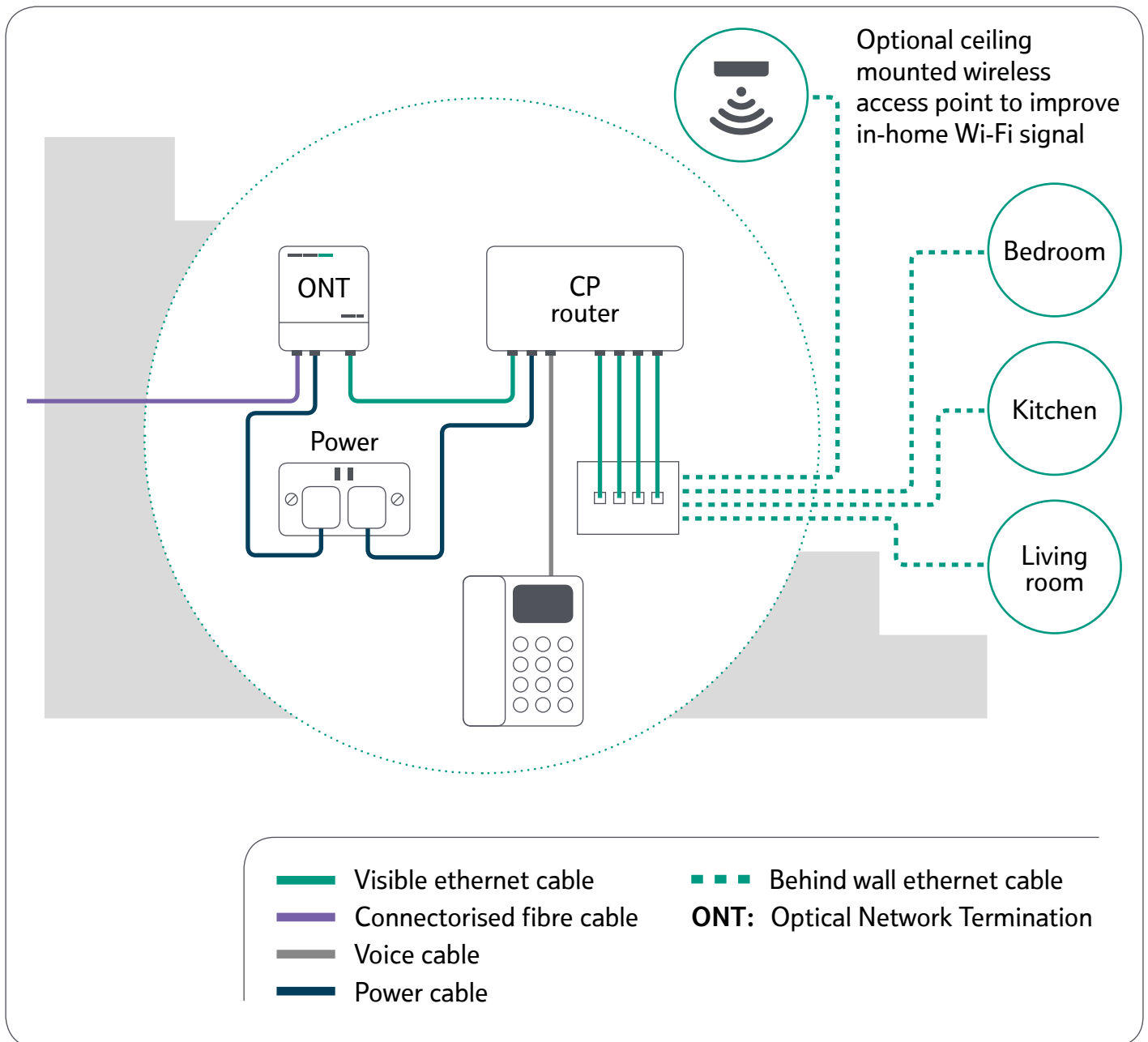

### Option 1: The simple install

The simplest installation will be the provision of the Openreach equipment (i.e. the ONT will be positioned adjacent to the outside wall) to which the customer then attaches the router, provided by their communications provider.

This installation limits the number of physical connections to the router and means the homeowner may not make the most of their FTTP connection due to the reliance on wireless connectivity.



## Home wiring

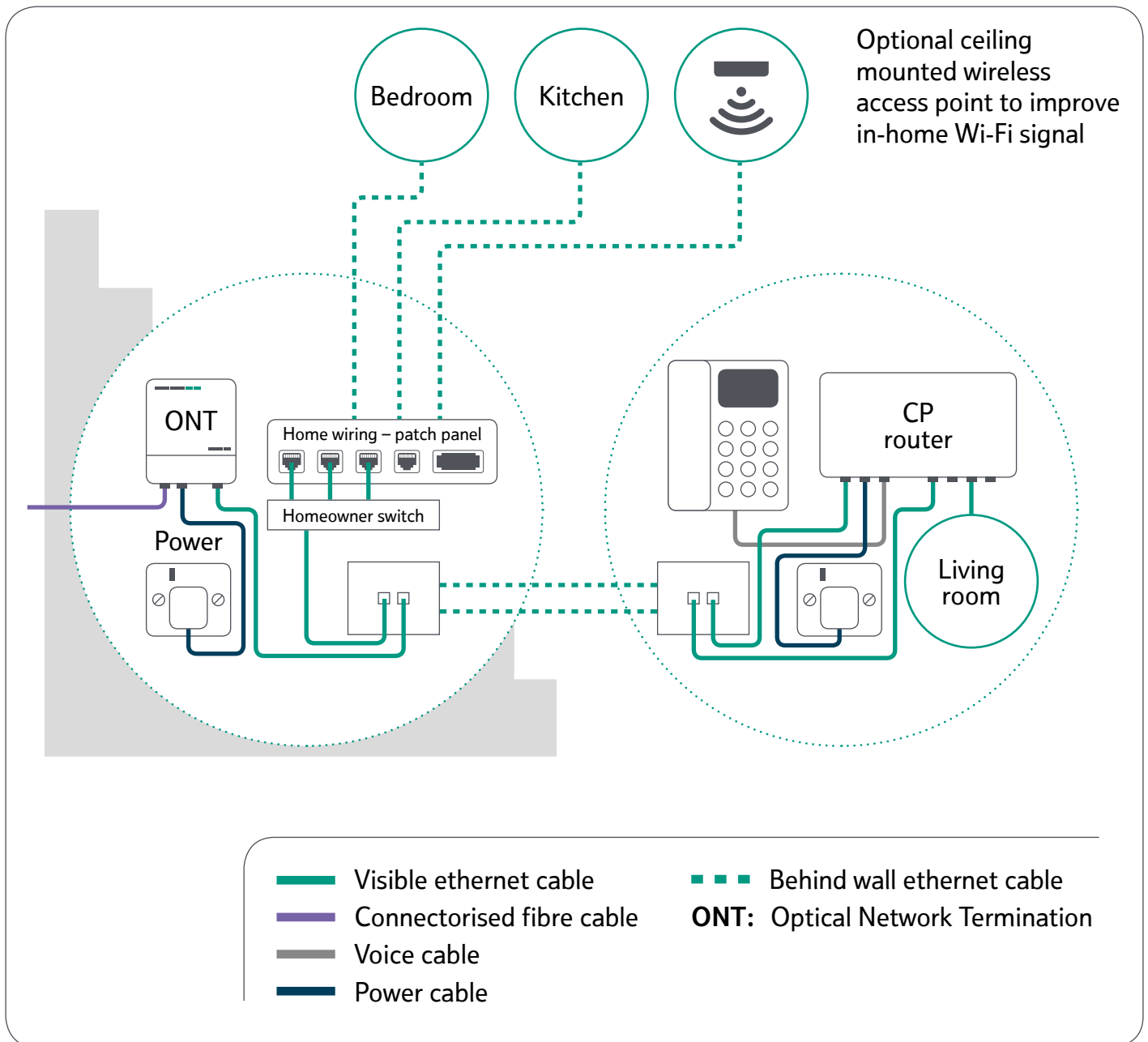

### Option 3: The networked home

Further to the second option, this setup cables back from the CP router position within the property to the under stairs/service cupboard position of the Openreach ONT for the location of a patch panel. This means that, as much as possible, any structured cabling is discreetly located out of sight.

A patch panel is the best option to intelligently connect multiple rooms with structured cabling. In this setup a customer could also install an ethernet bridge/switch to further create a truly networked home.



## Home wiring

# Provision of the Openreach equipment

When Openreach install the equipment we will install the ONT wherever the incoming fibre cable is located. Where you self-install the ONT, you will have control over when the equipment is installed. The ONT will remain the property of Openreach in both installation scenarios.

Where you are self-installing the Openreach equipment we will supply the ONT and the connectorised internal fibre cable you need. If you are installing the ONT opposite the cable entry hole, you will need to install a flush mounted double back box on the internal wall where the ONT is to be located.

The ONT will be installed at this location unless an alternative position has been agreed with your FBC and the appropriate connectorised internal fibre cable run in a continuous fault-free length to the alternative position.

While the provision of internal wiring beyond the Openreach ONT is the responsibility of the developer, you can contract an Openreach engineer to do this work for you. If interested, please contact your local customer network solutions team on 0800 783 2023. Terms and Conditions for the provision of internal wiring will apply.

### Please note

If connectorised cable is damaged by developers during installation then an internal Splice Point may be required to be fitted to complete installation. This will be undertaken at commissioning stage by Openreach.

# Installation of internal cabling

## Voice Cabling

- Voice extension cabling shall run direct from the ONT voice port. Connection to the ONT is made via a BS6312 431A Plug inserted into voice port 1. This socket must be a slave socket, not a master socket.
- Extension sockets shall be located close to power sockets for easy equipment connection. A minimum of 50mm between telephone cables and power cables must be left throughout.
- Where this isn't practical, telephone and power cables must be separated by an acceptable divider (i.e. of rigid, non-conducting material).
- Extension wiring must be telephone/data grade and have plain annealed solid copper conductors of a diameter between 0.5mm and 0.63mm. The conductors must be in twisted pair format. The conductor resistance shall be of a maximum of 96 ohms/km. The cable sheath must be PVC.

## Data Cabling

- As a rule of thumb connectorised internal fibre cables must not exceed the minimum bend radius (i.e. no smaller than) of a £2 coin.
- Detailed information on cable installation and separation is given in the British Standards.
- Code of Practice 6701, Part 1 (particularly clause 6) and the relevant sections of the latest IEE Regulations for electrical Installation (Regulation 525 is of particular importance).
- The wiring pattern for cabling must be either in series or spur. For data it must be point to point as speeds will be impacted after the first point of a daisy chain.
- We'd recommend data cabling rooms likely to benefit most from a physical connection, like the room with the main TV and the home office.

## 3 Developer self-install

### Internal Work at defined ONT and Communications Provider router position

- Fit the double electrical socket to the wall.
- Fit the double back box to the wall.
- Fit the slave voice socket to the wall (can be modular to house one voice port and one data port).
- Fit RJ45 modular boxes. The number of these are to be determined by you the developer Openreach recommend a minimum of two are fitted, one for the communications provider router and the other to the room requiring streaming media for example for streaming high definition TV. See the internal wiring section for further information.
- All internal wiring to be run back to this point (daisy chain for voice and point to point for data).
- See below for the recommended layout of sockets on the wall, the layout can be mirrored.

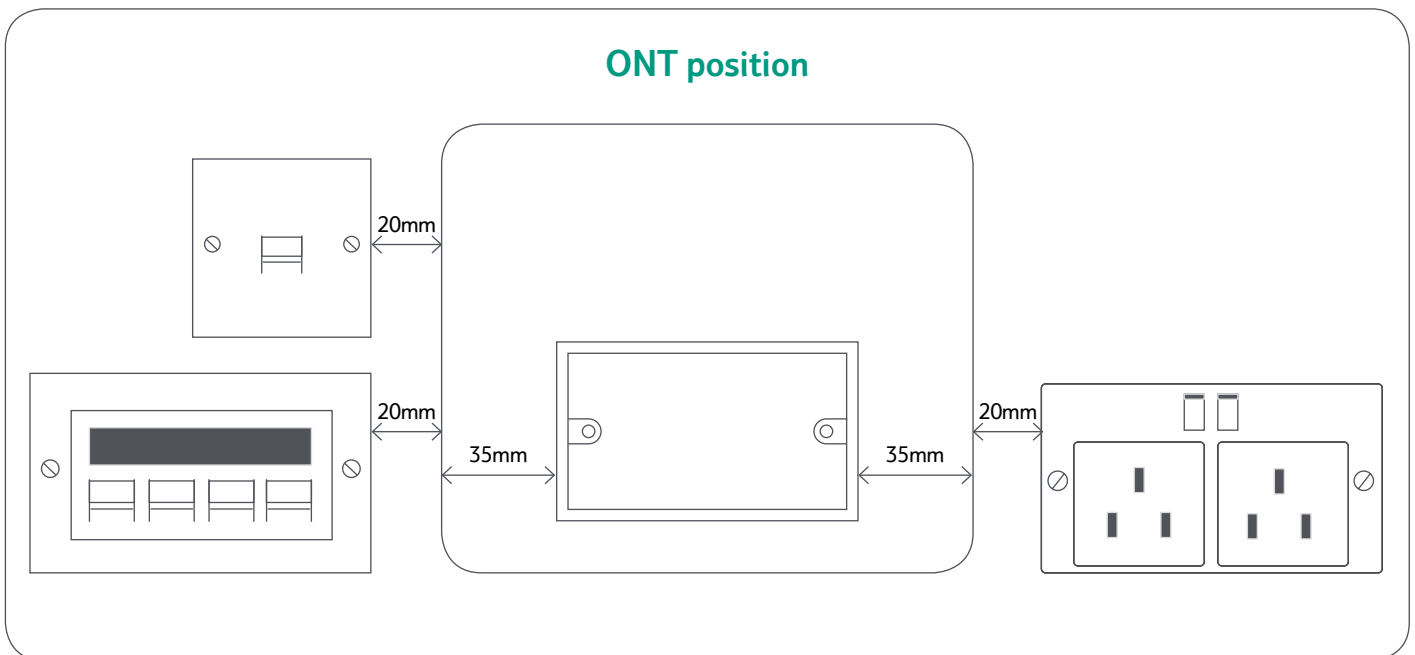

### Single Dwelling Unit at second fix (Internal Work)

- Fit the enclosure to the wall over the double back box using the supplied template.
- Take the pre-connectorised cable from back box to the ONT position.
- Clean both the pre-connectorised cable and the optical port of the ONT before inserting the cable.

**A video showing the installation of the internal equipment can be found on the Openreach developer website at the following link:**

[www.ournetwork.openreach.co.uk/property-developers/developer-handbooks-and-extra-services.aspx](http://www.ournetwork.openreach.co.uk/property-developers/developer-handbooks-and-extra-services.aspx)

## Developer self-install



Remove the cap from the green fibre connector and use the One Click cleaner to clean both the connector and the optical port on the ONT. Once cleaned plug into the Optical port on the ONT. Care must be taken at this stage not to contaminate the end of the fibre connector to avoid any dirt from inhibiting the data signal.

### Please note

**Fujikura are our chosen producer of fibre cleaners. The One Click cleaner shown here can be found at the following link:**

[www.fujikura.co.uk/products/fibre-and-optical-devices/connectivity-and-cleaning/one-click-cleaners/](http://www.fujikura.co.uk/products/fibre-and-optical-devices/connectivity-and-cleaning/one-click-cleaners/)



Open the green flap on the Optical port and insert the fibre cable. The cable is designed to fit only one way, so ensure the raised nodule is facing the wall when inserting.

- Connect the ethernet cable to the PORT 1 port on the ONT. The other end of this cable will be connected to the CP router once ordered.
- Connect the telephone cable to the TEL 1 port on the ONT and plug into the Slave socket on the wall (this cable is a separate item and will be provided by your FBC).
- Connect the mains adaptor to the ONT and plug into the mains socket.
- You can see the final layout and cable connections here, ensure the cable lengths are correctly positioned within the enclosure before continuing.



## Developer self-install

### DSI next steps

- Once plot is complete contact your Openreach FBC as each plot is ready for connection (i.e. front door on; power on, ONT area decorated).
- Your Openreach FBC will then raise a job with the Openreach teams to commission the plot(s).

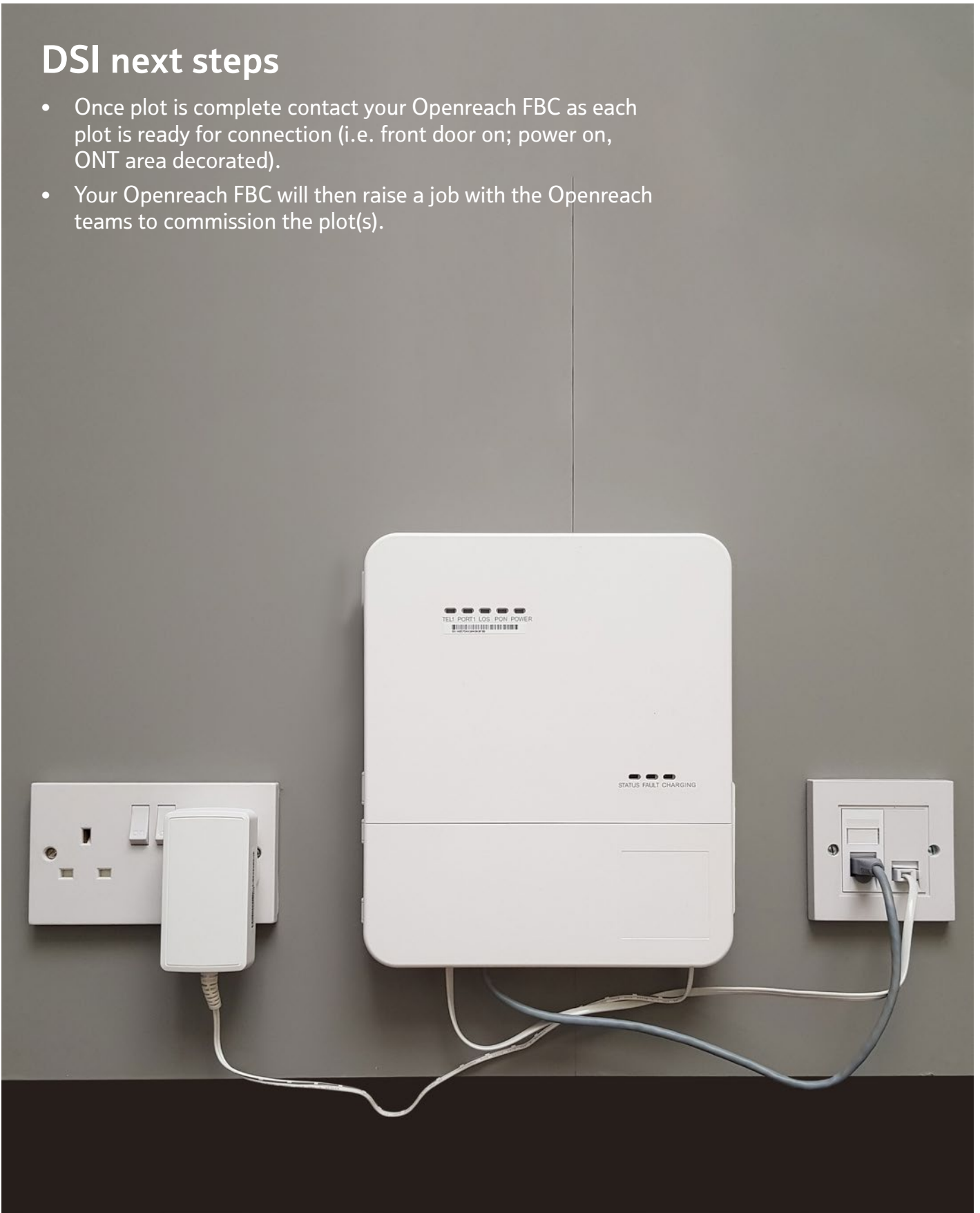

## 4 Cabling and ONT positioning

### Single dwelling units

For Single Dwelling Units a pre-connectorised cable will be available in different lengths (2m, 5m, 10m, 20m and 30m) and will come in individual bags that can be ordered via the FBC. Enough cable must be left coiled or connector under capping/EF externally to connect to the connectorised cable coming from the duct.

Once the connectorised cable is installed then Openreach (or their third party) will visit to connect the cables from the plot back to the serving splitter location(s), mount the external capping and then commission the plot.

### Installation of pre-connectorised cable at first fix (Internal Work)

#### Step 1

The dual connectorised cable should be installed externally to internally, as only the green SC-APC connector needs to go to the ONT mounting point. Feed the cable through the external wall to the mounting point. The bend radius of cable must meet all necessary installation requirements i.e. no 90 degree bends. Make sure to leave the protector cap on the connector until the Openreach installation is complete.

#### Step 2

Coil 1m of pre-connectorised cable into the empty double back box, taking care not to damage the green connector and fit a blanking plate to help protect the fibre. Ensure the caps on the end of the green connector are kept on during construction to avoid damage to the fibre cable. Coil the excess cable outside of the property ready for Openreach to connect. The amount of cable coiled should be the distance from the service hole to the ground + 0.5m. Ensure the black capping is kept on the external cable to avoid damage to the connectorised components.



## Cabling and ONT positioning

### Complying with Building regulations

Even where you are not working with Openreach or another infrastructure company to provide a functioning broadband and phone infrastructure to the home the Part R regulations require the provision of duct in the default position discussed below so that infrastructure can be installed in the future.

### ONT in the default position

When the ONT is to be fitted in the default position on an internal wall directly opposite the entry position of the service access hole adjacent to the external duct location, external capping will be fitted on completion.

To keep things tidy, make sure that the service access hole is drilled in line with the duct and in keeping with the dimensions shown below.

The service will be sealed with a grommet or mastic before fitting the external capping.

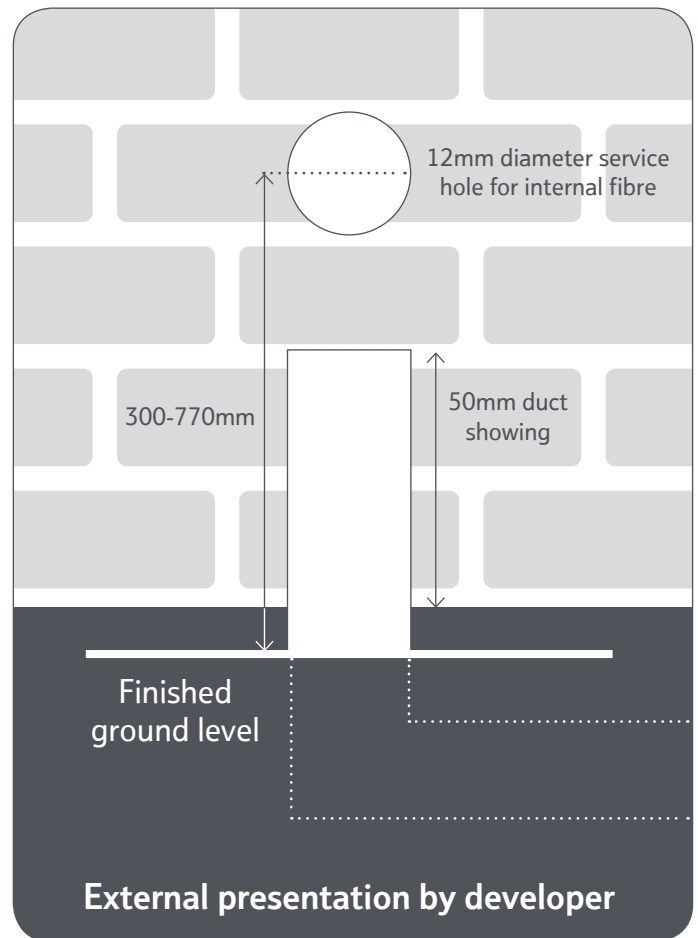

#### Please note

All internal wires and sockets beyond the Optical Network Terminal (ONT) are the responsibility of the developer/future home owner. Any faults or defects resulting in an Openreach visit may incur a charge.

## Cabling and ONT positioning

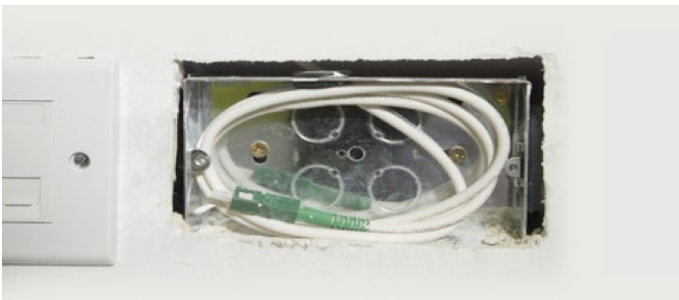

Wherever possible, the duct shall be positioned on the opposite side of the wall to where the ONT will be installed, removing the need to run internal fibre cables. However, there are cases where the kit will need to be installed away from the external lead in and your FBC will be able to advise.

When Openreach is to install the Openreach ONT and connect the internal and external connectorised cables, two metres of cable is required at external end and 1m (or 2m for non-connectorised cable) at the internal point of the installation. It shall be left coiled and housed/ protected within a flush mounted double back box and faceplate ready for Openreach provision of ONT.

## ONT installed inside the house (non-default position)

When the ONT is to be fitted in a non-default position i.e. not directly behind the external entry point, such as in a utility cupboard, the above guidelines must be followed to provide entry of the cable into the home.

What will be different is the length of cable that will run from the entry point into the building to the Openreach ONT. In this case you have the responsibility of running the connectorised internal fibre cable required inside the house in such a way that it is undamaged and complies with building regulations for the installation of telecommunications infrastructure cabling.

The same rules apply to the running of fibre cable internally that are specified in the section on exterior ducting. For example, the installation of the fibre cable in protective conduit and the absence of a bend more than 90°. Once installed the ONT must be kept powered on.

If this option is followed but the cable is found to be damaged once in situ, either during installation, damage sustained by construction work inside the property, or damage subsequent to the home owner occupying the property,

then unless you at your expense opt to replace the damaged fibre cable during commissioning of the property, Openreach will install the equipment in the default location within the home using surface mounted cables and charge accordingly.

The developer must run the connectorised internal fibre cable in a continuous length and it must remain free from any damage that could reduce the lifespan of the cable, and keep the capping on the connectorised cable until the installation is complete.

When Openreach is to install the Openreach ONT and connect the connectorised fibre cable, two metres of cable is required at external end of the installation and 1m internally. It must be left coiled and housed/protected within a flush mounted double back box and faceplate (or could be a brushed faceplate if preferred) ready for Openreach connection of external fibre cable and ONT nearby.

When the developer is installing the Openreach ONT 2m of cable is required at the external entry point and 1m at the ONT location.

## Cabling and ONT positioning

Interconnecting voice lead (Item Code 077004) will be provided free of charge by Openreach. It provides connectivity from the ONT to a co-located voice socket/patch panel. On installation it becomes the property of the home owner. Alternatively, the developer may choose to hardwire directly into a voice socket using a 431A Plug.

### Multiple Dwelling Unit (external)

- Fit all external duct from the site connection point to the building entry position.
- Fit all tray work from the building entry position to and up the risers to the internal splitter position(s).
- Run the fibre cable from the splitter or fibre node/budi location to (and in) the riser to the communications room.
- Coil a minimum of 2m in the communications room.
- Coil a minimum of 2m at internal splitter position.
- Ensuring bend radius of cable must meet all necessary installation requirements i.e. no 90 degree bends (as per current copper process).
- If there is a comms room it has to be within 2m at point of entry.
- If the risers are away from the point of entry but is fed through a vented car park then the external cable can be fed on tray work.
- If the risers are away from point of entry and is fed through a non-vented car park then an area needs to be allowed within 2m of point of entry to change from external to internal cable.

### Multiple Dwelling Unit – Next Steps

- Once ductwork and cable has been run from communications room to Fibre DP contact FBC to gain confirmation that all cables are run correctly.
- FBC will then raise a job with the Openreach Internal teams to commission the splitter(s).
- Once commissioning is complete contact FBC as each plot is ready for connection (front door on power on, ONT location is decorated).
- FBC will then raise a job with the Openreach internal teams to commission the plot(s).

### Ensuring fire safety with internal cabling

Once ductwork and cable has been run from communications room to splitter – contact FBC to gain confirmation that all cables are run correctly. FBC will then raise a job with the Openreach Internal teams to commission the splitter(s). Once commissioning is complete contact FBC as each plot is ready for connection (front door on power on, ONT location is decorated). FBC will then raise a job with the Openreach internal teams to commission the plot(s).

### Fire stopping compartment penetrations

All holes drilled through floors and fire compartment walls must be fire proofed using correct materials to prevent the spread of smoke in the event of a fire. Openreach can provide these materials in either cartridge (similar to silicone sealant) or putty form.



## Cabling and ONT positioning

### Fixing cables securely

If you're running any cables through a fire protected area like a fire escape route, escape staircase or walkway, the cable must be adequately secured using non-combustible fixings.

Wiring regulations must be followed, ensuring that wiring systems in escape routes are supported in such a way that they will not be liable to premature collapse in the event of fire. This applies to all cabling and not just electrical cables e.g. alarm, telecoms and control wiring. From January 2019 this will apply throughout the installation as the 18<sup>th</sup> Edition wiring regulations come into force.

- Limit duct runs to a depth of 250mm on footway, 450mm on soft ground or 600mm if shared carriageway surface at house end.
- The Openreach duct must be no greater than 15mm from the finished wall surface.
- The duct must protrude no more 50mm from the finished ground level.
- A draw rope must be installed between the joint box and the duct at the property wall.
- The duct opening must be covered, preventing the ingress of debris.
- Ducting from property to the footway boxes must be laid 4-6 weeks before the plots are handed over.

### Issues with home wiring

- Connectorised fibre cable too short, cut or damaged.
- Defective or damaged home wiring creating a fault on the line.
- Extension sockets not connected to Openreach ONT.
- Bending radii exceeded causing reduced levels of service due to fibre being broken or the bend was too tight.
- Incorrect cable type or wiring configuration.

### Impact on delivery

- Inability for Openreach to provide service and developer requirement to re-provide connectorised fibre cable.
- Poor user experience for home purchaser with possibility of Openreach charges if called upon to rectify.
- Slower data download speeds experienced.

### Impact on delivery of issues

- Delay in completion – Openreach may refuse to cable if we can't guarantee adequate protection.
- The capping and covers would look unsightly.
- Failure to provide conduit can prevent a cable from being installed.
- Customers may not be able to place orders and remedial work may incur additional costs.

### Typical issues with duct presentation

- Duct not cut to the appropriate height from the finished ground level.
- Duct installed too shallow.
- Duct protruding too far from the finished wall surface.
- Duct not lining up with internal fibre cable lead in.

# 5 Multi Dwelling Units (MDUs)

Openreach will create a fibre layout based on your Mechanical & Electrical (M&E) drawings (on larger MDUs) of the MDU. The design will calculate the stores required to build the network. Your FBC is on hand to guide you through the ordering process to make sure the equipment is available when you need it. The incoming Duct 54 and fibre cable will terminate in the communications intake room or riser cupboard. This needs to be a secure and safe location with access for installation and any future maintenance visits.

Our fibre box/splitter needs to be installed at a minimum height of 200mm and a maximum of 1500mm. Your FBC will agree the location with you. Connectorised internal fibre cable needs to be run from each plot to the fibre DP location or basement box, depending on MDU layout. A minimum of 3m of coiled cable needs to be left at the fibre DP, with 1m left at the plot end. A wayleave may be required from the building owner prior to installing apparatus in common areas. Remember you may need to order copper, for example: for lift lines.

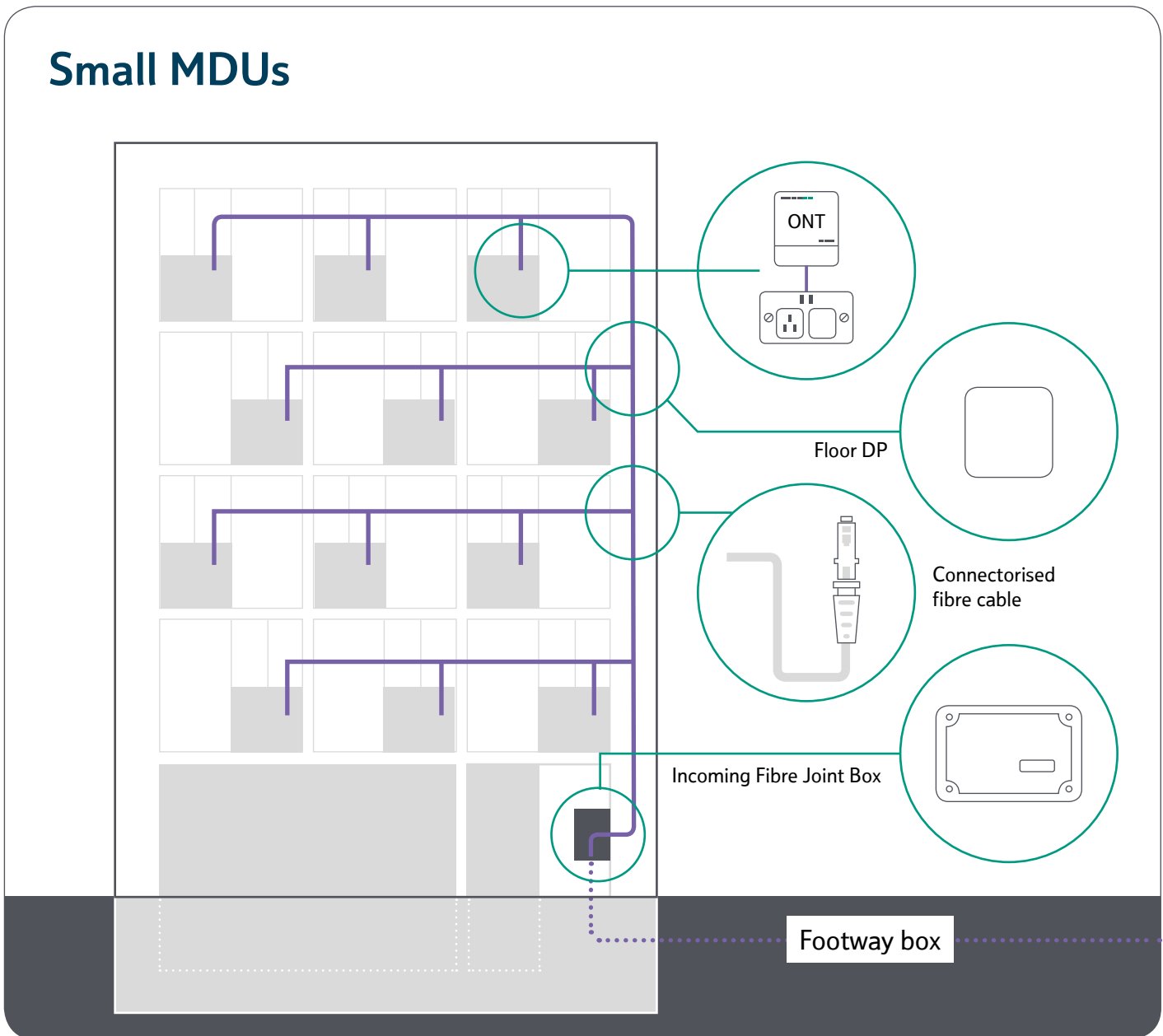

Multi Dwelling Units (MDUs)

# Large MDUs

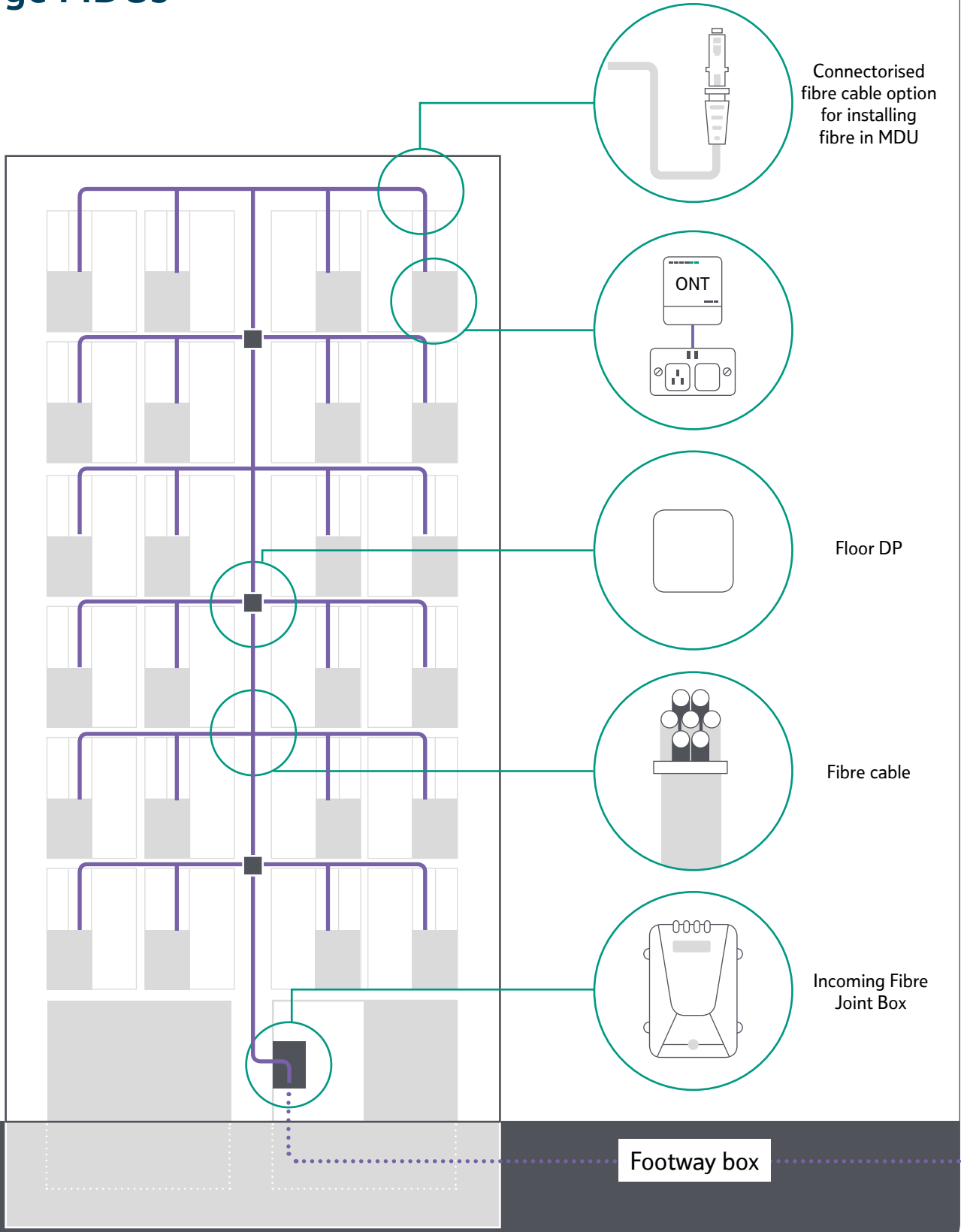

## Multi Dwelling Units (MDUs)

For larger MDUs there may be a requirement to install multiple fibre boxes splitters.

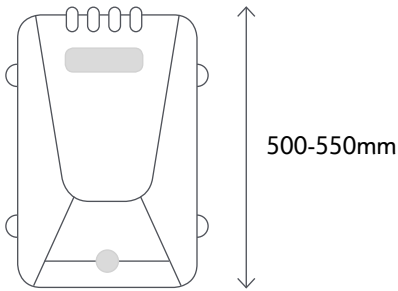

These boxes/splitters will be connected with Duct 54 and fibre cable commonly housed within the riser space.

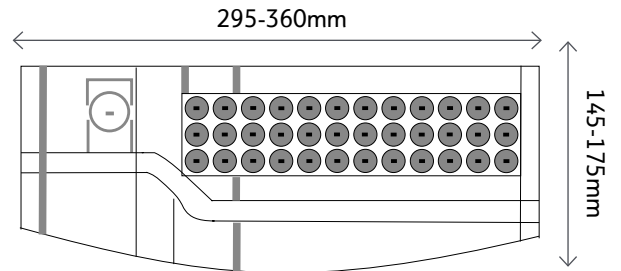

## Maisonettes

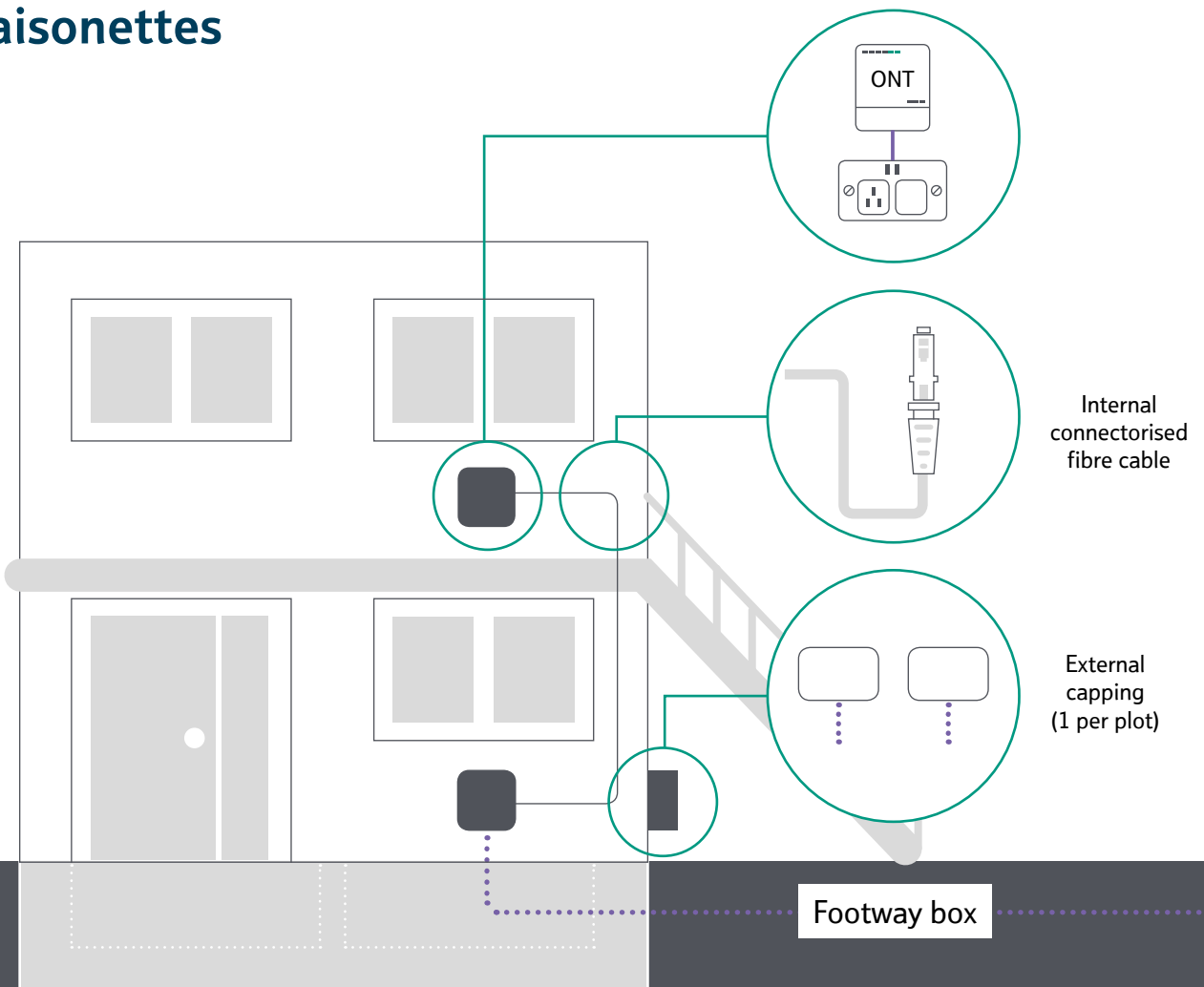

## Multi Dwelling Units (MDUs)

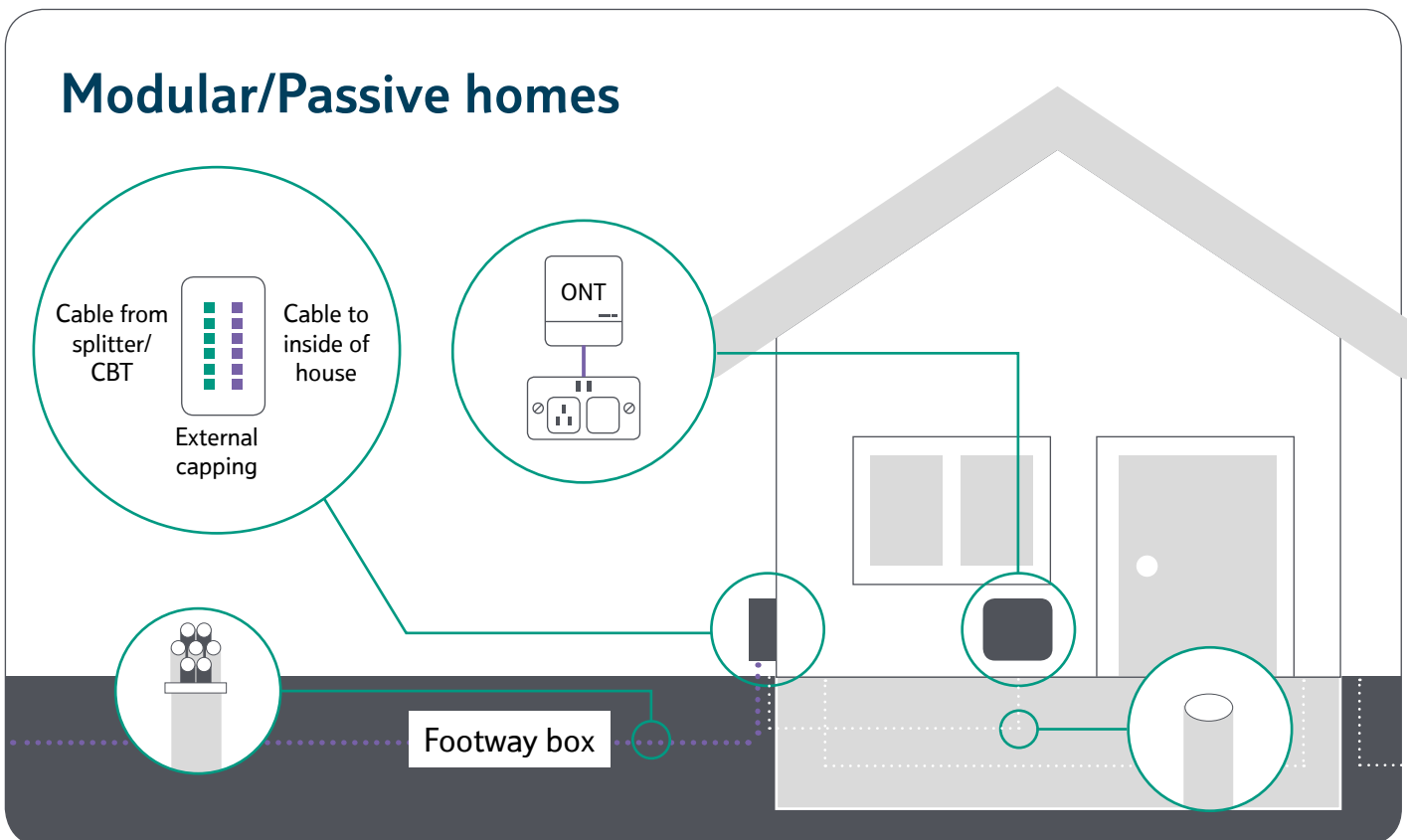
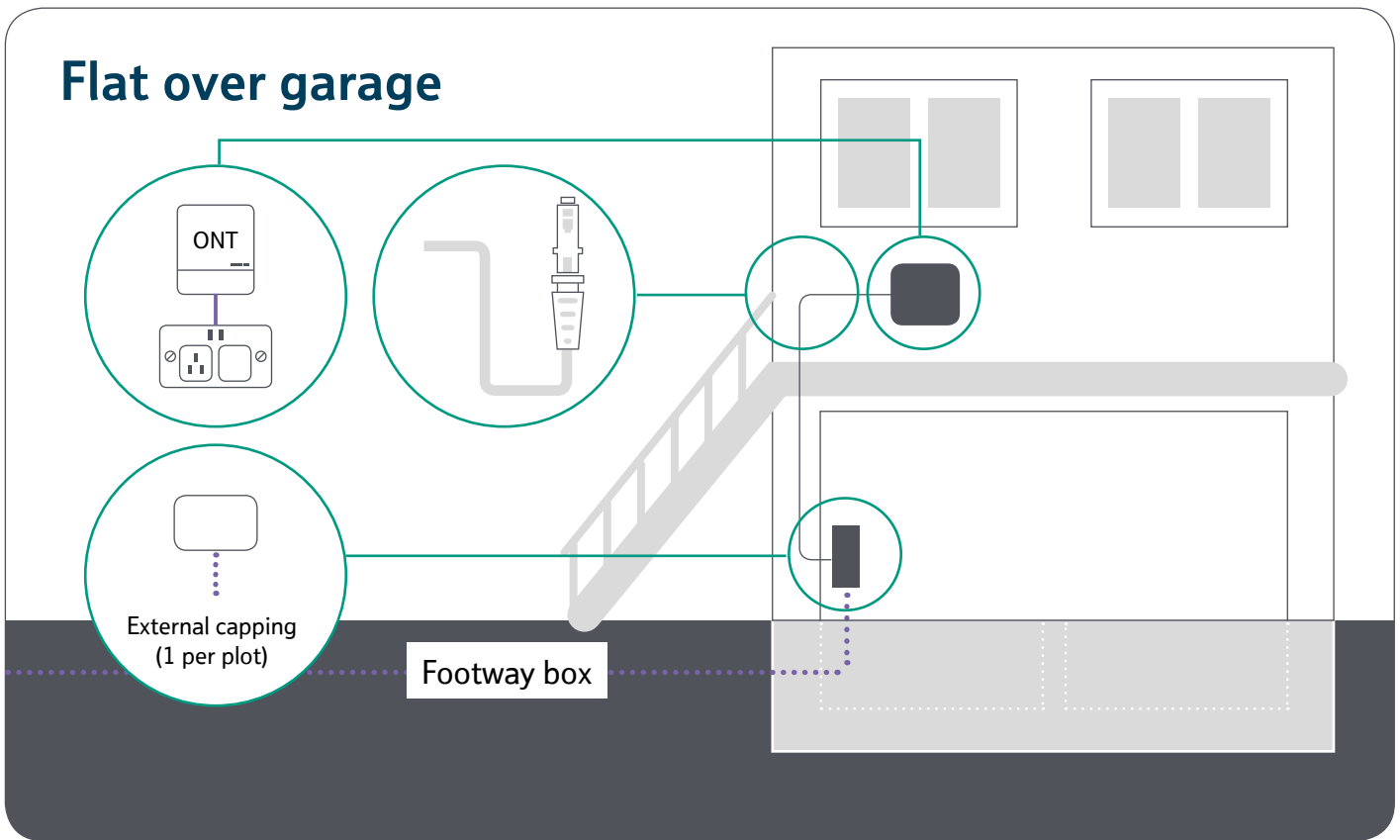

## Multi Dwelling Units (MDUs)

### Option where Openreach installs the equipment

When Openreach is to install the ONT, 3m of cable is required at the splitter/ floor DP location and 1m (2m if non-connectorised cable) at the ONT end of the installation.

Each apartment will require a designated connectorised internal fibre cable run in a continuous fault-free condition from the designated ONT location within the apartment to the floor DP within the riser.

At the splitter locations the cable should be clearly marked with the apartment number and left safely coiled within the riser.

- Install a flush mounted double back box at the desired ONT location.
- Install the connectorised fibre cable from this point to the designated riser termination point.
- Ensure there is 1m of spare connectorised fibre cable protruding from the back box.
- Push some of the spare cable back into the wall void and coil the remainder inside the back box, taking care not to damage the connectorised end.
- Install blanking plate or brushed face plate to protect cable ready for provision of ONT nearby.

Bends in fibre cable must be kept to a minimum and the installation of trunking, cable trays/grids shall not compromise the bending radii.

Fibre cable containing no metal parts can be run on shared trays.

Plate cable fixings with cable ties must be used to fix fibre cable direct to walls to avoid it being damaged.

Under no circumstances should cable or tubing be secured or supported to the suspended ceiling hangers or under floor support legs.

It is the developer's responsibility to provide fire stopping on completion of the cable/ tubing installation.

Openreach networks must not interfere with or be interfered with by other services within the riser or any other shared space. e.g.

- Un-insulated hot water pipes.
- Unscreened mains cables.
- Fluorescent lighting.
- Heavy duty switch gear.

A wayleave may be required from the building owner prior to installing apparatus in common areas. Remember you may need to order copper lines for commercial properties, for example lift lines.

Your FBC will advise of all cable marking/ labelling and will check for this when 'calling off' the work.

IET wiring regulations shall be followed.

External cables can run to a maximum of 2m from the internal building entry point.

From this point onwards, all cables must meet current fire regulations. The alternative is to house all cables in metallic trunking.

Internal fibre cable must not be bent beyond its minimum radius. If it has been damaged or there is evidence of kinking it shall be discarded. Your FBC will advise on replacement of the cable.

Care shall be taken to avoid stretching cable/ tubes through installation. If cables are damaged this way you will be required to replace them.

# 6 Commercial units

## Small or Medium Enterprise (SME) unit on a residential development

Internal connectorised fibre cable

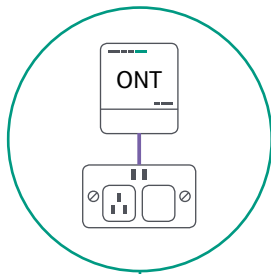
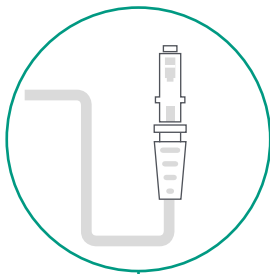

**Please note**  
The ONT position within the building is to be agreed between the FBC and the developer on site.

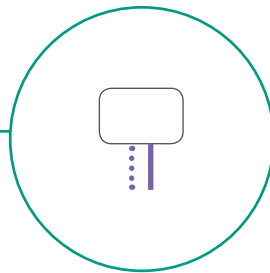
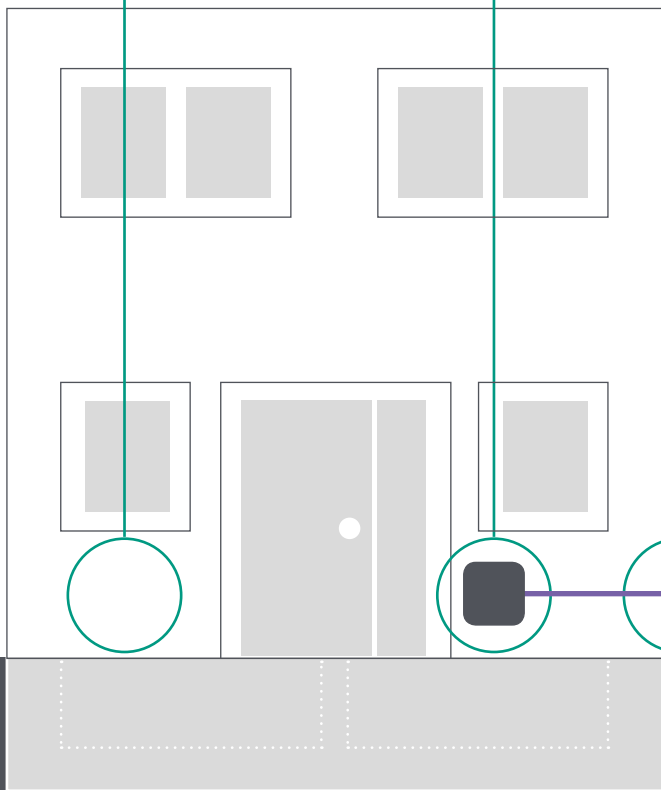

External capping

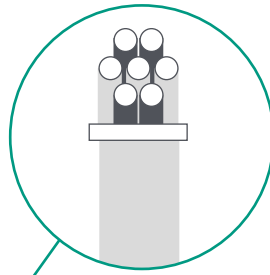

External fibre cable

Footway box

## Commercial units

### SME within an MDU

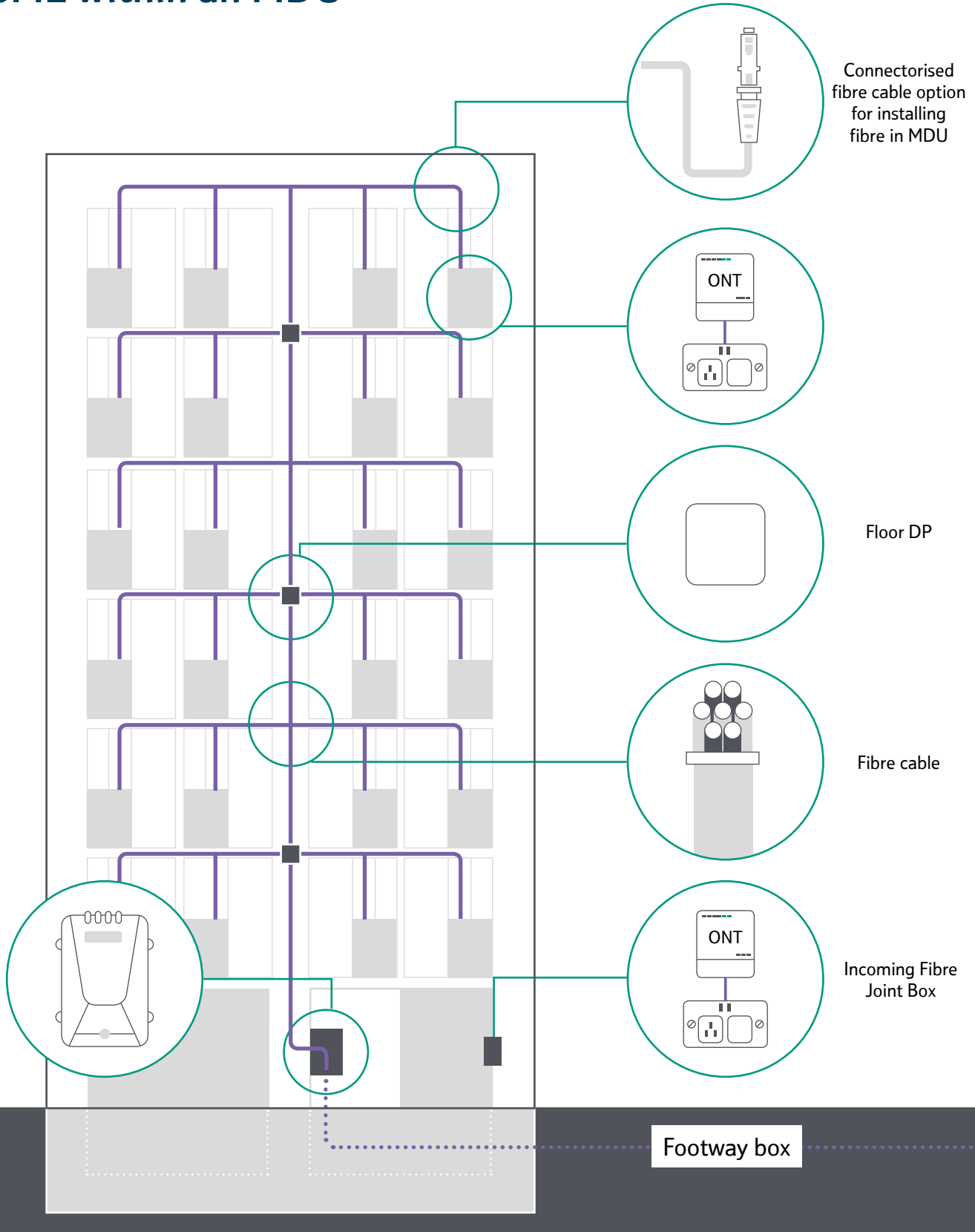



Commercial units

# Commercial unit within a commercial only site

Internal connectorised fibre cable

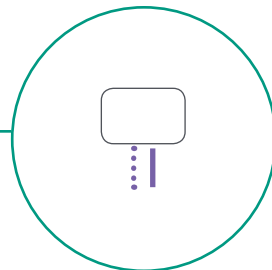
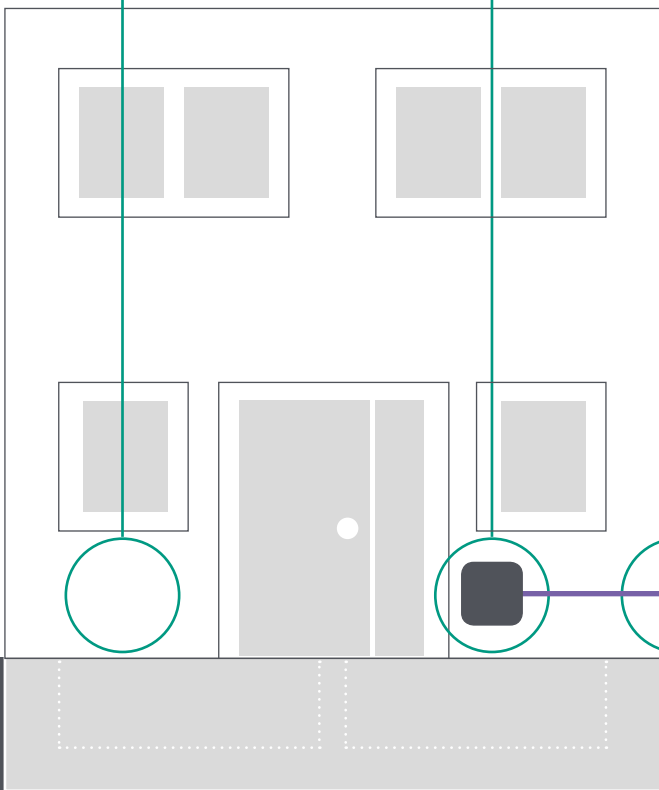
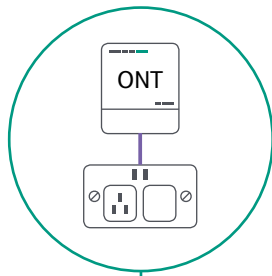
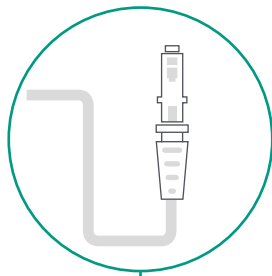

External capping

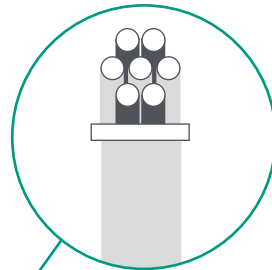

External fibre cable

Footway box

# 7 Duct laying

## Carriageway Road Crossings

Where our duct crosses a carriageway, adjoining kerbs must be temporarily marked to note positions. Openreach duct must be laid on an outer edge of the service trench to enable box building. A draw rope will be inserted through the duct and secured to the marker posts at both ends of the crossing. The appropriate Plug Duct 4B socket end and 4C Spigot is then fitted.

Duct laid beneath a carriageway crossing must be a minimum of 450mm depth from the cover of the final surface levels and, for engineering reasons (Streetworks UK), separated from other services laid in parallel by 600mm (to permit us to install underground joint boxes without the need for bends).

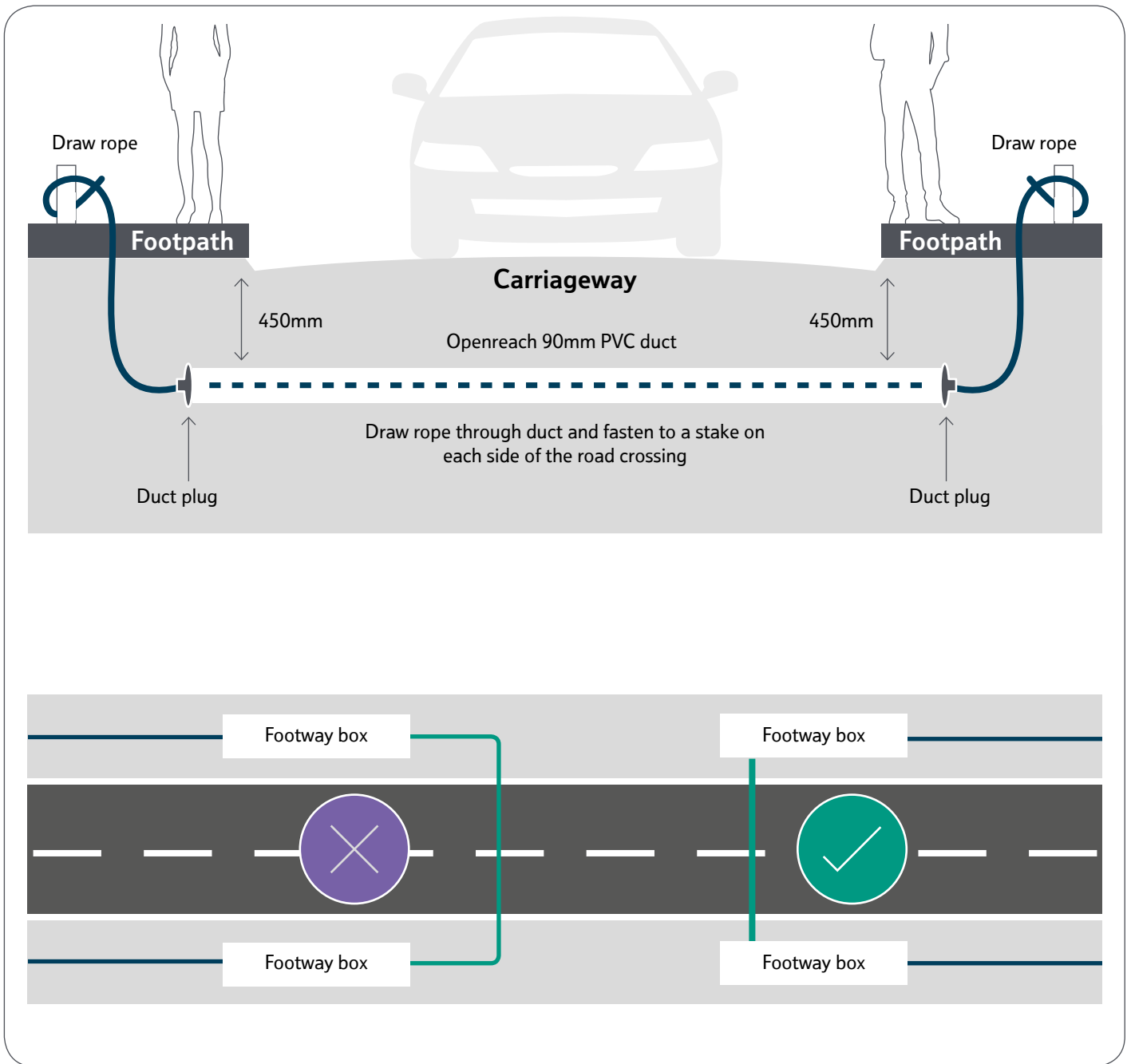

## Duct laying

### Ducting to the building

Duct to the premises/building must be laid at a minimum depth of 250mm and be as straight as possible.

### Ducting general principles

- All runs shall be laid as straight as possible. If needed, you can carefully bend the ducts or use pre-formed bends supplied by Openreach.
- There shall be no more than one pre-formed 90° bend in any single run of duct.
- Pre-formed 90° bends shall not be installed in any duct linking two joint boxes.
- Footpath or service strip ducting must be laid at a minimum of 250mm depth of cover.
- All space alongside the duct must be backfilled with granular fill to a minimum thickness of 75mm.
- For all Single Dwelling Units (SDU) duct must be terminated on the external surface of the property.
- The duct termination point must be in a location that will allow unrestricted access for any future maintenance activity.
- All ducts must be provided with a draw rope after installation, unless it's agreed locally to substitute the draw rope with a cable.
- Please notify your FBC when the duct has been laid and is ready for inspection.

### Commercial unit ducting

- 90mm duct can be laid either externally or internally to the building, with 45 degree angled bend.
- If internally then the duct should be sealed once cabling is complete – the FBC will provide this as a stores item.
- The termination point on a large commercial unit within a commercial only site should be located within 10m of the entry point.

#### Please note

The latest information on the positioning of utilities, mains and plant can be obtained from Streetworks UK: [streetworks.org.uk](https://streetworks.org.uk)

## Duct laying

# Arrangement of mains services

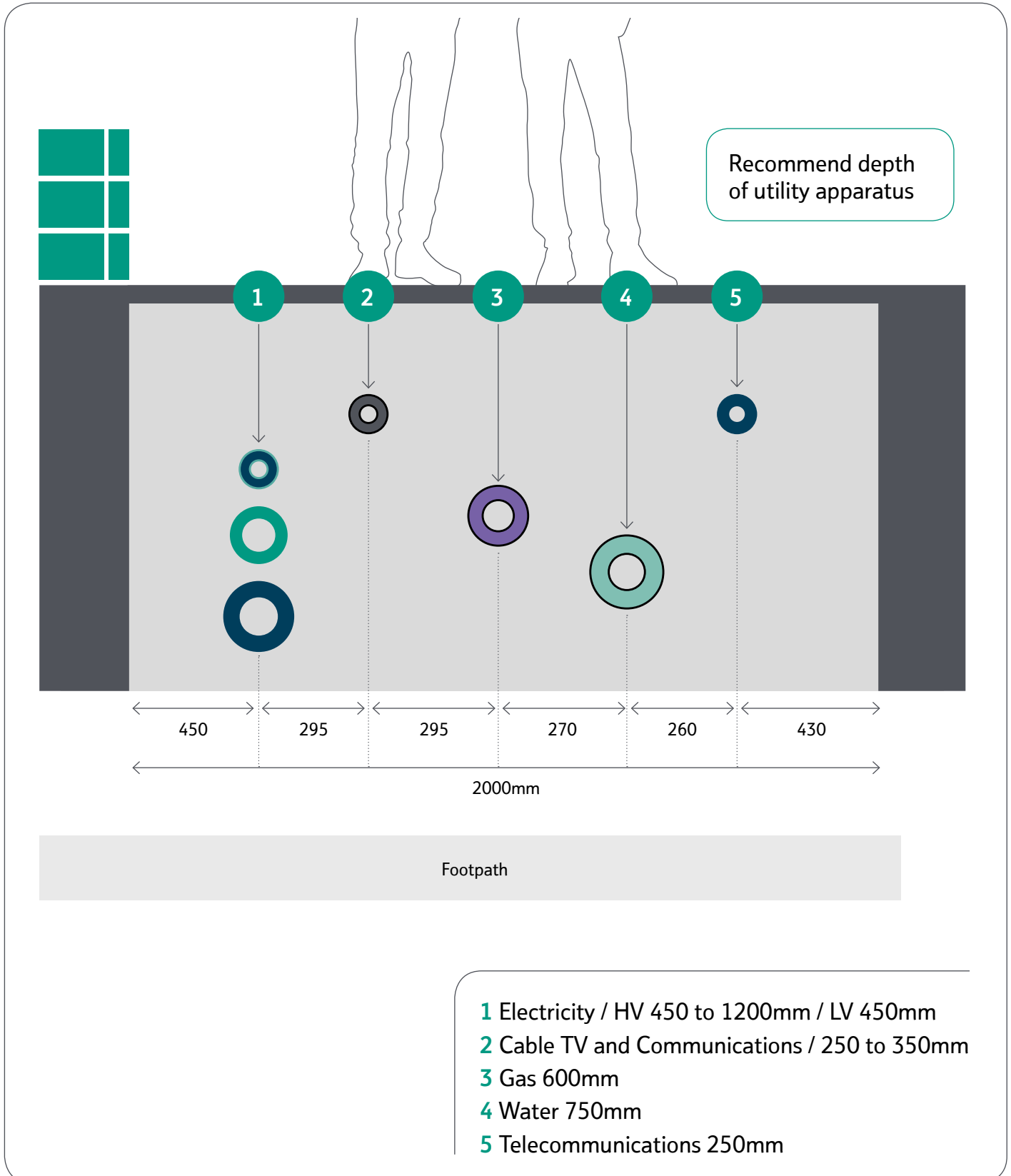

## Duct laying

# Avoiding damage to the Openreach underground network

Openreach has an extensive underground network that can be located inside / on the perimeter of a site.

This network is vulnerable to excavation related damage unless appropriate precautions are taken.

The precautions for avoiding damage to an underground utility plant are contained within the Health & Safety Guide no. 47: “Avoiding danger from underground services”.

This document stresses the need for the availability of utility plans on site and the use of safe digging practices.

**Available here:** [www.hse.gov.uk/pubns/books/hsg47.htm](http://www.hse.gov.uk/pubns/books/hsg47.htm)

Damage to the Openreach network by a third party can be expensive for that party to repair.

**By working together, we want to make sure you avoid the repair and associated cost which can consist of one or more of the following:**

- **Direct Cost** – the cost of repair.
- **Operational Cost** – delays associated with repair.
- **Social Cost** – loss of service to emergency services/ centres or the vulnerable in society.

### Typical issues with carriageway road crossings

- Insufficient depth.
- Proximity to other services.

### Impact of issues

You will have to renew duct and this may delay any first occupation date or subsequent occupation dates.

## Click Before You Dig

**To obtain a more precise location of Openreach infrastructure (either within your site or the adjoining land) and avoid costly damage, contact:**

**email: [cbyd@openreach.co.uk](mailto:cbyd@openreach.co.uk)**

Utilisation of the Openreach “Click Before You Dig” free service has a proven record of minimising the potential for damage and cost.

If you need to move or consult on existing Openreach equipment, contact us on **0800 783 2023** or complete the online webform at **[www.ournetwork.openreach.co.uk/help-and-support.aspx](http://www.ournetwork.openreach.co.uk/help-and-support.aspx)**

## 8 Modular jointing chambers – Quadbox™

The optional approved pre-formed chamber system Quadbox™ can be used to speed up the installation process and bring significant productivity benefits as there is no need for specialist box building teams and concrete backfill to be used.

The Quadbox™ is not a free stores item from Openreach, but can be purchased directly from our approved supplier, Cubis Industries: [www.stakkabox-quad.com](http://www.stakkabox-quad.com)

Joint box modular footways 104 and 106 are the Openreach approved versions (BT specification LN712).

Box furniture items slot into moulded pockets within the chamber, eliminating the need to cast-in fixings or drill on site. Duct entries are also easy to achieve, using a standard hole saw mounted on a cordless drill.

The lightweight high-strength system is supplied as 150mm deep twin wall high-density polyethylene (HDPE) rings to provide maximum flexibility and strength which are simply stacked on a prepared base and backfilled with suitable as-dug or Type 1 material.

See the suppliers Installation Guide Which comes with your box.

If purchasing a pre-formed chamber you are required to purchase the associated furniture.



## Modular jointing chambers – Quadbox™

### Furniture

Cable brackets and steps (where required) are supplied in a bagged kit and easily slot into purpose designed pockets in the chamber. The brackets and steps drop into preformed slots.



#### Available Size Range

Product Code	Clear opening	Depth Per Section
JMF104	915X445mm	150mm
JMF106	1310X610mm	150mm

### Duct entries

Duct entries can be cut as and where required using a hole saw mounted on a cordless drill.

The chambers incorporate guides which identify drilling points to ensure correct duct spacing.

A maximum of 4 duct entries can be made into a single wall of the Quadbox™.



### Quadbox points of note

As with brick built chambers, care should be taken to make sure:

- The box is set at the correct depth and the base/ plinth is installed correctly.
- The side wall is not damaged/misshapen due to over compaction.
- The frame is level with the surface and a core drill is used for cutting duct entries.
- The developer is required to purchase the required wall bearers.

## 9

## Joint boxes, footways and frames &amp; covers

## Footway (JBF104/106)

Joint box designs and specifications may vary depending on the duct layout and whether multi-way ducts or major road crossings need to be incorporated into the network design.

Full technical drawings and specifications are available at [www.openreach.co.uk/propertydevelopments](http://www.openreach.co.uk/propertydevelopments)

## Materials

- **Bricks:** BS EN771-1. Stretcher Bond.
- **Cement:** BS EN197-1:2000 ordinary mix. Three parts sand to one part cement.

## Specifications

- **Base:** 150mm concrete, clean and level.
- **Brickwork:** Keyed in at the corners and pointed.
- **Frame and cover:** Set on a mortar bed and fitted squarely to the box structure. You can purchase lifting keys for the covers from TW Engineering Co Ltd at [www.twtools.co.uk](http://www.twtools.co.uk) (tel: 0115 932 3223).
- **Duct entries:** Must not enter through corners and be no less than 75mm from the side wall. They shall enter wall at a minimum depth of 250mm from the top of the frame, cut flush and clear the base by a minimum of 100mm.
- **Bolts:** Must be fitted in each box to allow ironwork to be installed by the developer.
- **Step(s):** One step is required in all boxes deeper than 700mm.
- **JBF104(C):** 915mm(L) x 445mm(W) x 750mm(D).
- **JBF104(D):** 915mm(L) x 445mm(W) x 900mm(D) the minimum depth for boxes either side of road crossings.
- **JBF106(C):** 1310mm(L) x 610(W) x 750(D).

- **JBF106(D):** 1310mm(L) x 610(W) x 900(D) the minimum depth for boxes either side of road crossings.
- **All backfill material** to be class 6N type.
- **Workmanship, materials and method of construction** are to comply with all current relevant contract documents, British Standards and codes of practice for the construction industry.
- **Concrete** to be grade C32/40 with a water cement ratio 0.4 minimum. Cement content 380kg/m<sup>3</sup>. Aggregate maximum size 20mm. All in accordance with BS8500.
- **All ducts** shown are based on maximum recommended values for Duct Type 54D.
- **End ducts** to be inline.
- **Ducts** to be positioned not less than 75mm from a side wall.
- **Mesh** to be grade B500B or B500C conforming to BS4483.
- **Short lengths of Duct 54D 90mm** to be used on non-ducted routes. Appropriate duct to be used on ducted routes.
- Where instructed to do so drill one set of three holes using a 12mm **masonry drill** bit to a depth of 80mm for future fitting of equipment mounting bracket.
- For details and specs on using corbelling visit the [link](#) at the top of this page.

## Please note

At no time must minimum box depth be compromised. Consult your FBC if the minimum depth cannot be achieved.



Joint boxes, footways and frames & covers

## Joint box footway 104 – the preferred option

Internal dimensions. Brickwork Stretcher Bond.

Dimensions in mm (not to scale).

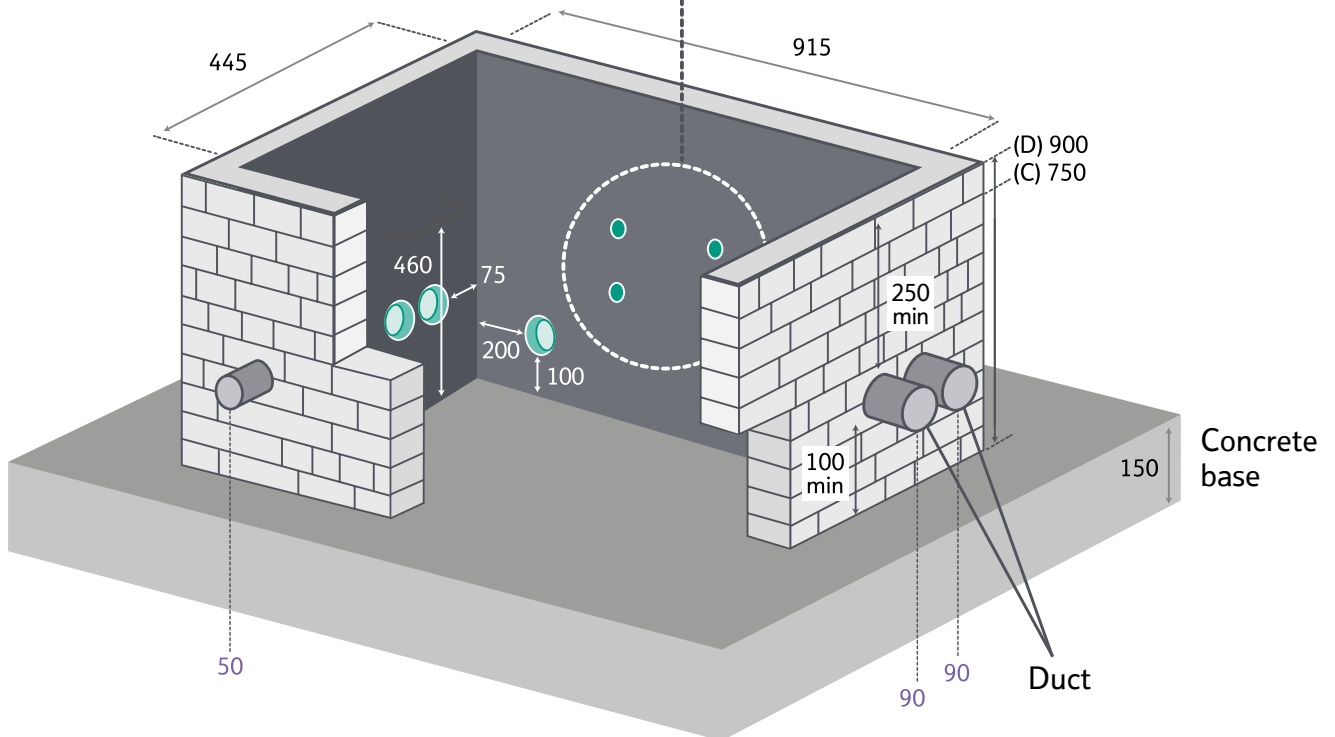
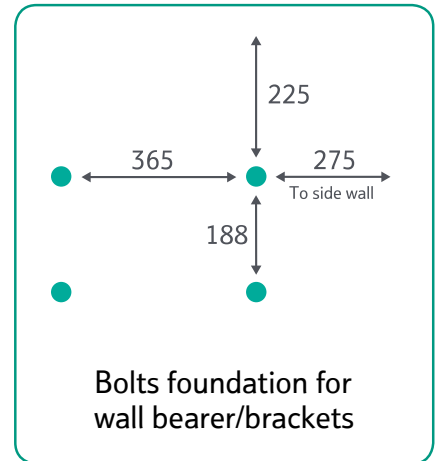

Joint boxes, footways and frames & covers

# Joint box footway 106

Internal dimensions. Brickwork Stretcher Bond.

Dimensions in mm (not to scale).

- Minimum depth for road crossing 450mm
- Sump to be fitted in boxes deeper than 700mm

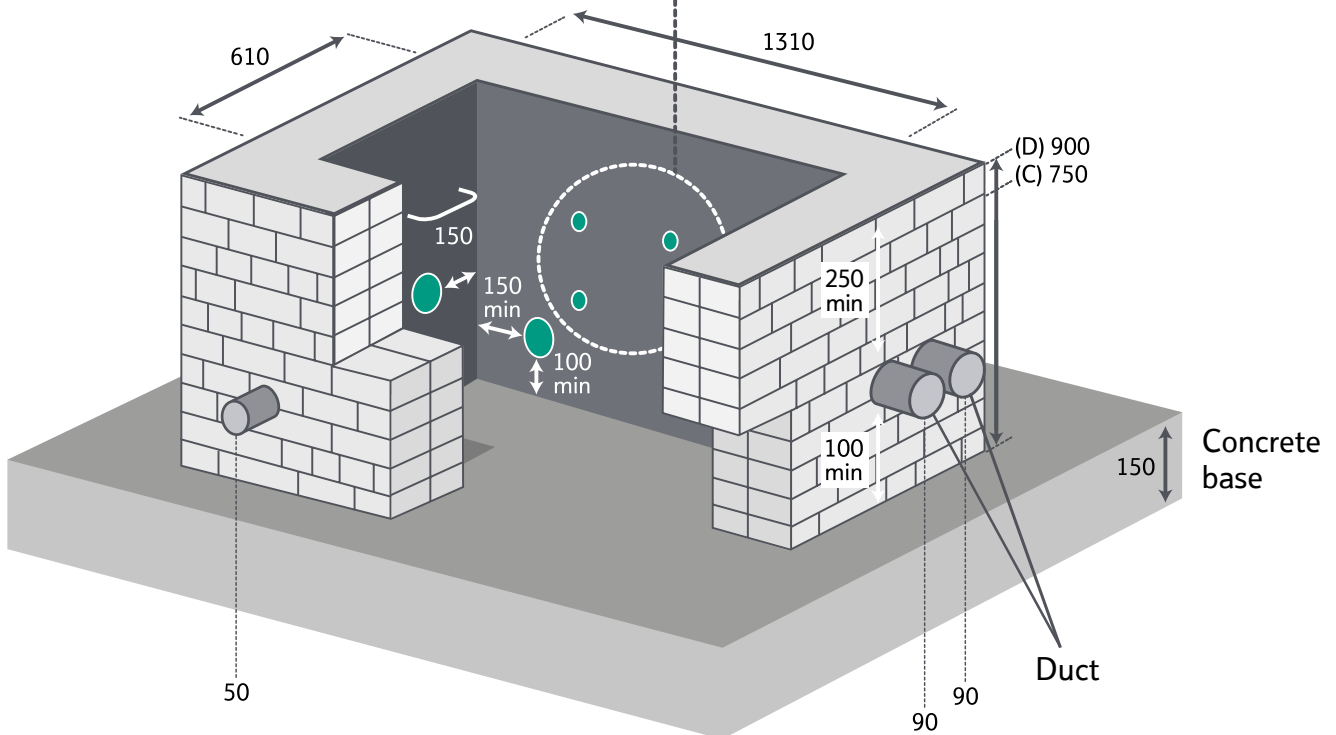
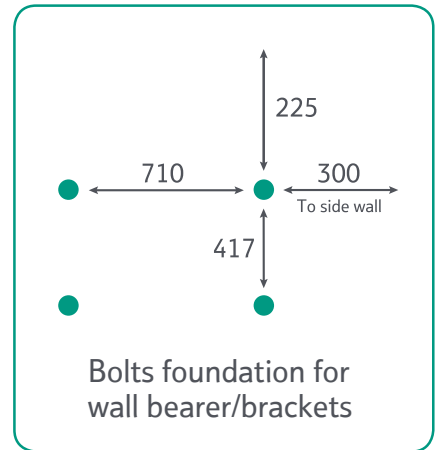

## Joint boxes, footways and frames & covers

### Carriageway JBC4

Box design and specifications may vary. This will be determined by the duct lay-out and whether multi-way ducts or major road crossings need to be incorporated into the design.

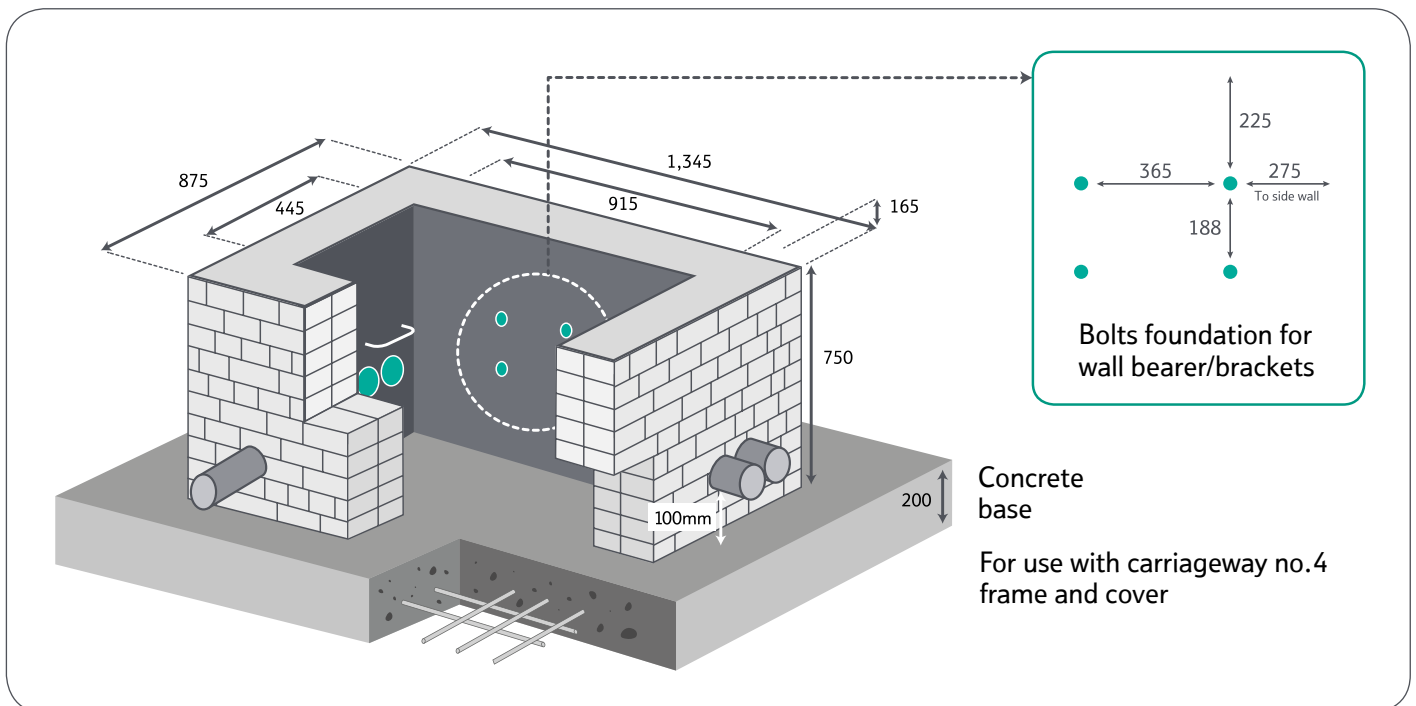

#### Materials

- **Bricks:** BS EN771-1. English Bond.
- **Cement:** BS12 Portland Cement.
- **Concrete:** BS EN206 Grade 32/40 concrete.
- **Mortar:** BS5628, Part1 requirement for mortar Table 1, Type (i).

#### Base

- **Cement:** BS12 Portland Cement.
- **Concrete:** 200mm concrete Grade 32/40, reinforced with A393 grade mesh at 70mm cover.

#### Brickwork

- **Bricks:** BS EN771-1. English Bond.
- **All brickwork** to be keyed in at corners and pointed.
- **Brickwork** to be 'English Bond' constructed with a 10mm joint thickness of cement mortar.

#### Frame and cover

- **Frame and Cover Carriageway no.4** to be squarely set on a mortar bed Highway Agency standards HA104.

#### Lifting keys

- **Key Joint Box Lifter** should be used to lift the cover and can be purchased from TW Engineering Co Ltd at [www.twtools.co.uk](http://www.twtools.co.uk) (tel: 0115 932 3223) or similar supplier of your choosing.

#### Duct entries

- Duct to be cut **flush** to the internal box wall.
- Duct **must not enter through corners** and be no less than 75mm from the side wall.
- Duct to enter wall no less than **450mm** from the top of the frame.
- Duct to be no less than **100mm** from the box base.

## Joint boxes, footways and frames & covers

### Frames and Covers

Cubis Industries is the only supplier of these Openreach approved products.

Only approved frames and covers shall be fitted on your site. They are identifiable by the following markings; 'EN24 B125' the British Standards kitemark the Manufacturer Mark (SID), the year of manufacture and the BT identifier.

The 'standard frames and covers' are supplied by Openreach. They consist of a galvanised steel fabricated frame, fitted with unfilled galvanised steel fabricated cover trays and cross-beams.

All covers can be fitted to brick or concrete.

#### Please note

Where there's evidence or high risk of vehicles using the soft verge e.g. as an undertaking area opposite a T-Junction, a passing point on a narrow road or a parking area, it will be necessary to install a 'carriageway chamber, frame and cover'. **There is also an optional 'recessed frame and cover'.**

### Recessed frames and covers

These can be purchased by the installer as an option to the 'standard frame and cover'.

Each cover tray has two key-hole fittings (in the centre of the short side) one of which carries a BT identity mark and the manufacturers' three letter identification 'SID'. The other key-hole fitting displays EN124 and B125 together with the BSI Kite mark certifying the covers to BS EN124: 1994. Recessed frames and covers will accommodate infill blocks to a maximum depth of 60mm. If you're planning to install frames and covers that aren't supplied by Openreach e.g. for block paving, or you have any doubts about what frames and covers to use, please speak to your FBC.



## Joint boxes, footways and frames & covers

### Installation

All frames and covers shall be levelled to the final running surface.

Where a box is located within a grass, soft or unmade surfaces, the frame shall be surrounded with a 100mm wide strip of minimum grade C25/30 concrete, to the full depth of the frame, finished level with the top edge of the frame and the outside edge. It must be straight and parallel to the frame.

### Unapproved frames and covers

Unapproved frames and covers must not be fitted. Openreach will take any necessary action against any developer who fits unapproved frames and covers within the network, including any potential claim for damages and costs, with possible delayed Service On Demand (SOD) payments. If you're unsure how to specify approved covers, please contact your FBC.



## 10 List of abbreviations and acronyms

Openreach maintains that all reasonable care and skill has been used in the compilation of this publication. However, Openreach shall not be under any liability for loss or damage (including consequential loss) whatsoever or howsoever arising as a result of the use of this publication by the reader, his servants, agents or any third party.

In the event of a discrepancy between the contents of this document and the contract, the terms and conditions shall take precedence. This is a living document and will be subject to update and change. The information within this document is provided for information purposes only. The Contract and Price List takes precedence.

<b>BBU</b>	Battery Backup Unit
<b>BSI</b>	British Standards Institute
<b>BT</b>	British Telecommunications
<b>CLI</b>	Customer Lead In
<b>CP</b>	Communications Provider
<b>DP</b>	Distribution Point
<b>FDP</b>	Fibre Distribution Point
<b>FTTP</b>	Fibre to the Premises
<b>FBC</b>	Field Based Coordinator (formally New Site Representative)
<b>HDPE</b>	High-Density Polyethylene
<b>IET</b>	Institute of Engineering and Technology
<b>JBC (N)</b>	Joint Box Carriageway New Sites
<b>JBF</b>	Joint Box Footway
<b>LSZH</b>	Low Smoke Zero Halogen
<b>MDU</b>	Multiple Dwelling Unit
<b>MJF</b>	Product code designation for the Cubis Industries–StakkaBox/Quadbox
<b>M&amp;E</b>	Mechanical & Electrical
<b>NJUG</b>	National Joint Utilities Group
<b>NTE</b>	Network Terminating Equipment
<b>NTP</b>	Network Terminating Point
<b>ONT</b>	Optical Network Termination
<b>PAS</b>	Publically Available Specification
<b>PE</b>	Polyethylene
<b>PVC</b>	Polyvinyl Chloride
<b>RFH</b>	Reduced Fire Hazard
<b>SID</b>	Manufacturers three letter identification
<b>SDU</b>	Single Dwelling Units
<b>SOD</b>	Service on Demand
<b>UG</b>	Under Ground

## 11 Health and safety advice

This guidance is a practical aid for designers and site workers on what to eliminate, avoid and consider when working on the Openreach network on your site.

The advice is not exhaustive so speak to your Field Based Co-Ordinator (FBC) if you need further information.

### Red lists

**Hazardous procedures, products and processes that should be eliminated from the project where possible**

#### Distribution point (DP) location

- Placing DPs into voids or other enclosed spaces with inadequate ventilation.
- Placing DPs adjacent to, or above, any fragile surface.
- Placing DPs directly above, or adjacent to, water features/ courses etc.
- Locating DP at greater than 1.5 meters above finished floor level (without fixed access system incorporated into design).

#### Power systems

- Ensure all power installation meet relevant standards, and where DC supplies are planned seek further advice about requirements for earthing of racks, power supply ratings etc. to take account of future needs and growth.

#### Cabling routes and lead-ins

- Routing of cables where the cables are above head height within false ceiling systems without a proper access system incorporated.
- Routing of cables external to building requiring specialist access methods (scaffold, mobile elevating work platform etc.)
- No internal ducting laid into Single Dwelling Units (SDUs).

#### Aerial and antenna transmission/ receiver systems

- Not mounted on building walls or other difficult to reach areas of a building.
- Design of roof mounted services that require access (for maintenance and so on), without provision for safe access (such as barriers) in particular access for aerials/ antennas systems.

## Joint boxes, footways and frames & covers

### Amber lists

**Products, processes and procedures to be eliminated or reduced as far as possible and only specified or allowed if unavoidable. Including amber items would always lead to the provision of information to the principal contract or contractor where only one contractor has been appointed.**

#### Distribution point (DP) location

- DP's located into voids or enclosed spaces provided with ventilation systems built in.

#### Aerial and antenna transmission/receiver systems

- EMF exclusion zones adequately managed with fixed barriers or partitioning systems.

#### Cabling routes and lead-ins

- Routing of cables where the cables are above head height within false ceiling systems.
- Routing of cables internally where access points require use of access equipment (ladders, step-ladders or platform steps) to allow for pulling in of cables.

### Green lists

**Products, processes and procedures to be positively encouraged.**

- **Adequate access for vehicles** to minimise reversing requirements (one-way systems and turning radii) in particular if specialist vehicles will need access (pole erection units, MEWP vehicles etc.).
- **Provision of adequate access and headroom** for maintenance in communications rooms, and adequate provision for replacing heavy components.
- **Thoughtful location of mechanical and electrical equipment**, such as telecoms equipment, termination points, Wi-Fi transceivers etc. and so on to facilitate access, and placed away from crowded areas.
- **Lighting within communications rooms** adequate for fine tasks (fibre splicing, small diameter copper wire terminations etc.)
- **Provision of adequate air handling/conditioning and ventilation** for the installed equipment base within the communications room (and people having to access and work within the area).
- **Early installation of permanent** means of access, and prefabricated access systems with hand rails.
- **Provision of edge protection** at permanent works where there is a foreseeable risk of falls after handover (consider radio antenna or aerials installations on roof spaces).
- **Encourage the use of engineering controls** to minimise the use of personal protective equipment.



## 12 Quality control checklist

To help make sure your site network is built to a high quality standard, we've produced a checklist for each phase of the build.

Any subsequent changes to the site plan after a checklist has been completed must be communicated and agreed with your FBC as soon as possible.

Any re-work as a result of an out of date site plan could cause delivery delay and incur you costs in time related charges.

**The Site Manager/ Developer Agent agrees to the quality standards and conditions.**

Signature: \_\_\_\_\_

Date: \_\_\_\_\_

If you have any questions about your development, please visit [www.openreach.co.uk/propertydevelopments](http://www.openreach.co.uk/propertydevelopments) or call us on 0800 783 2023

### The site

Developer	
Site Name	
Site Address	
Post Code	
Site Manager/ Developer Agent Name	
Telephone	
Email	
Openreach New Site Identity Ref.	

### Openreach Contact

New Sites Office	
FBC Name	
Telephone	
Email	
Off-site Connection Location	
First Occupation Date	
Site Start Date	

## Quality control checklist

Item being audited	Category	Checked and Acceptable Standard?			Comments
		Yes	No	N/A	
Base has been cast correctly.	Joint Box				
Reinforced base cast correctly for Joint Box Carriageway JBC (N).	Joint Box				
Bearers and brackets fitted. Steps fitted where appropriate.	Joint Box				
Bolts fitted and positioned correctly during construction of boxes.	Joint Box				
Joint Box constructed to correct dimensions and installed at the correct depth. Any deviations to plan recorded and signed off.	Joint Box				
All concrete/brickwork carried out as per developer 'How to' guide specification.	Joint Box				
Cement and brick types used as specified or exceptions agreed and documented.	Joint Box				
Frames and covers bedded and correctly installed (if unmade surface, Joint Box frame secured).	Joint Box				
Joint Box constructed as planned, positioned correctly and conforms to drawings. Alternatives agreed and documented.	Joint Box				
Modular box installed and prepared as per instructions.	Joint Box				
Ducts properly trimmed and keyed when set in walls.	Joint Box				
External cable/Blown Fibre Tubing (BFT) protected and sealed in Joint Box.	Joint Box				

## Quality control checklist

Item being audited	Category	Checked and Acceptable Standard?			Comments
		Yes	No	N/A	
Fibre cable and draw rope provided in sound condition and correctly jointed where applicable.	Duct				
Cable/BFT left in planned location.	Duct				
Correct rope/cables/tubing installed as per Developer 'How to' guide.	Duct				
Correct type of duct provided and used.	Duct				
Duct laid in required position, at correct depth and installed in the correct position in the Joint Box.	Duct				
Duct properly trimmed and keyed when set in walls.	Duct				
Duct separation distance maintained, or exception agreement obtained and documented.	Duct				
Ducts laid at minimum depth (350mm), or exceptions agreed and documented. (To be viewed in footway where possible, if not check via Joint Box).	Duct				
Joint Box constructed as planned, positioned correctly and conforms to drawings. Alternatives agreed and documented.	Duct				
Temporary duct seals fitted to agreed standard.	Duct				
Ducts positioned correctly on external walls and in line with the cable entry point.	Duct				

## Quality control checklist

Item being audited	Category	Checked and Acceptable Standard?			Comments
		Yes	No	N/A	
Ducts positioned in line with the cable entry point.	Plot				
Customer cable entries correctly positioned and provided.	Plot				
External cable/BFT protected and sealed.	Plot				
Duct seal Plug 1A fitted.	Plot				
Back box installed at entry point.	Plot				
Back box fitted at a usable depth, within close proximity to a double 240v outlet for FTTP services.	Plot				
Location of unit entry point suitable for FTTP equipment.	Plot				
The property has been designed to accommodate voice and data wiring in a convenient place for home owners to use FTTP services.	Plot				
A permanent 240 volt supply is required for FTTP. Developer has been informed that no orders can be made or taken via a Service Provider until all installation works of Openreach equipment into each plot has been completed and tested.	Plot				
Voice and data cabling provided and terminated correctly for FTTP services.	Plot				
If FTTP self install development ONT, BBU, all leads connected correctly and plot commissioned.	Plot				
If self install not completed and Openreach completes all internal work then SOD payment for self install is not applied.	Plot				

## Quality control checklist

Item being audited	Category	Checked and Acceptable Standard?			Comments
		Yes	No	N/A	
All tubes or cables presented as per schematic diagram and capped.	Multi Dwelling Unit				
Designated track ways/trays supports in good working order with separations maintained.	Multi Dwelling Unit				
Connectorised fibre cable installed as per schematic in accordance with Manufacturer's specifications and IET wiring regulations. Cable labelled and coiled safely within riser.	Multi Dwelling Unit				
Connectorised fibre cable installed with 1m of spare length protruding from the back box to enable jointing.	Multi Dwelling Unit				
Back box fitted in each unit at a usable depth, within close proximity to a double 240v outlet for FTTP connectivity.	Multi Dwelling Unit				
Location of unit entry suitable for FTTP equipment.	Multi Dwelling Unit				
If FTTP self install development ONT, BBU, all leads connected correctly and plot commissioned.	Multi Dwelling Unit				
If self install but Openreach completed all internal work then SOD payment for self install is not applied.	Multi Dwelling Unit				

## 13 ONT plot stickers

Plot #	ONT Barcode Sticker
<b>1</b>	
Address	
<b>2</b>	
Address	
<b>3</b>	
Address	
<b>4</b>	
Address	
<b>5</b>	
Address	
<b>6</b>	
Address	
<b>7</b>	
Address	
<b>8</b>	
Address	
<b>9</b>	
Address	

Plot #	ONT Barcode Sticker
<b>10</b>	
Address	
<b>11</b>	
Address	
<b>12</b>	
Address	
<b>13</b>	
Address	
<b>14</b>	
Address	
<b>15</b>	
Address	
<b>16</b>	
Address	
<b>17</b>	
Address	
<b>18</b>	
Address	

## ONT plot stickers

Plot #	ONT Barcode Sticker
<b>19</b>	
Address	
<b>20</b>	
Address	
<b>21</b>	
Address	
<b>22</b>	
Address	
<b>23</b>	
Address	
<b>24</b>	
Address	
<b>25</b>	
Address	
<b>26</b>	
Address	
<b>27</b>	
Address	

Plot #	ONT Barcode Sticker
<b>28</b>	
Address	
<b>29</b>	
Address	
<b>30</b>	
Address	
<b>31</b>	
Address	
<b>32</b>	
Address	
<b>33</b>	
Address	
<b>34</b>	
Address	
<b>35</b>	
Address	
<b>36</b>	
Address	

**ONT plot stickers**

Plot #	ONT Barcode Sticker
<b>37</b>	
Address	
<b>38</b>	
Address	
<b>39</b>	
Address	
<b>40</b>	
Address	
<b>41</b>	
Address	
<b>42</b>	
Address	
<b>43</b>	
Address	
<b>45</b>	
Address	
<b>46</b>	
Address	

Plot #	ONT Barcode Sticker
<b>47</b>	
Address	
<b>48</b>	
Address	
<b>49</b>	
Address	
<b>50</b>	
Address	
<b>51</b>	
Address	
<b>52</b>	
Address	
<b>53</b>	
Address	
<b>54</b>	
Address	
<b>55</b>	
Address	



**ONT plot stickers**

Plot #	ONT Barcode Sticker
Address	
Address	
Address	
Address	
Address	
Address	
Address	
Address	
Address	

Plot #	ONT Barcode Sticker
Address	
Address	
Address	
Address	
Address	
Address	
Address	
Address	
Address	





# openreach

[openreach.co.uk](https://openreach.co.uk)

The telecommunications services described in this publication are subject to availability and may be modified from time to time. Products and services are provided subject to British Telecommunications plc's respective standard conditions of contract. Nothing in this publication forms any part of any contract. Openreach and the Openreach logo are trademarks of British Telecommunications plc.

© British Telecommunications plc 2019.

Registered office: 81 Newgate Street, London EC1A 7AJ

Registered in England No: 1800000.

Produced by Openreach.

Designed by westhill.co.uk

PHME 84937